

EPTM Gun

313872P

EN

Plural Component, Impingement Mix, Mechanical Purge Pour Gun

For use with non-flammable foam in open pour applications. Not approved for use in European explosive atmosphere locations.

Model 257999, 24C932

3000 psi (20.7 MPa, 207 bar) Maximum Fluid Working Pressure
80-100 psi (0.55-0.69 MPa, 5.5-6.9 bar) Air Inlet Pressure Range
180°F (82°C) Maximum Fluid Temperature



Important Safety Instructions

Read all warnings and instructions in this manual. Save these instructions.

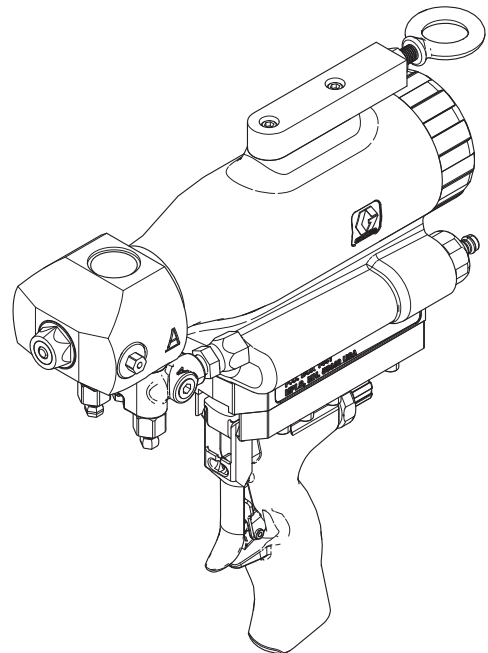

ti19547a



Contents

Related Manuals	3	Repair	32
Models	4	Tools Required	32
Orifice Flow Area Ratio Chart	4	Lubrication	32
Fixed Orifice Flowrate Data	5	Replace Cartridge	32
Variable Orifice Flowrate Data	6	Remove Front End	33
Warnings	9	Disassemble Front End	34
Important Isocyanate (ISO) Information	11	Assemble Front End	34
Material Self-ignition	12	Attach Front End	35
Keep Components A and B Separate	12	Pistons and Bulkhead	36
Moisture Sensitivity of Isocyanates	12	Purge Rod	37
Foam Resins with 245 fa Blowing Agents	13	Solenoid Valve	38
Changing Materials	13	Troubleshooting	39
Throat Seal Liquid	14	Electrical Diagram	41
Grounding	14	Parts	42
Piston Safety Lock	14	Kits	45
Trigger Lock	14	Series A and B Kits	45
Loss of Air Pressure	15	All Series Kits	47
Hook Support	15	Series C Kits	51
Component Identification	18	Orifice Kits	52
Cutaway View	19	Drill Bit Kits	53
Theory of Operation	20	Complete O-ring Placement Guide	54
Gun Triggered (Fluid Pouring)	20	Accessories	55
Gun Detriggered	20	Lubricant for Gun Rebuild	55
Setup	21	Fluid Inlet Cover	55
Adjust Orifices	22	Gun Cleaning Kit	55
Optional Hose Position	23	Flushing Manifold	55
Pressure Relief Procedure	24	15B817 Manifold Block	55
Shutdown	25	Circulation Manifold	55
Short Term Shutdown	25	Reactor [®] IP Harness	55
Long Term Shutdown	25	Signal Cable Extensions	55
Maintenance	26	Solvent Flush Canister Kit	56
Supplied Tool Kit	26	Solvent Flush Pail Kit	56
Lubrication	26	Grease Cartridge for Gun Shutdown	56
Grease the Gun	26	Technical Data	57
Flush Gun	27	Dimensions	58
Clean Outside of Gun	28	Graco Standard Warranty	60
Clean Breather Plug	28		
Clean Fluid Manifold	28		
Clean Check Valves	29		
Clean Fluid Housing Passages	30		
Clean Orifice	31		
Replace Mix Chamber and Front Seal	31		

Related Manuals

Manuals are available at www.graco.com.

Component manuals in U.S. English:

Power-Lock™ Heated Hose	
Part	Description
309572	Instructions - Parts
Solvent Flush Kits	
Part	Description
309963	Instructions - Parts
Circulation Manifold Kit	
Part	Description
309818	Instructions - Parts
Heated Hoses and Applicator Kits	
Part	Description
3A0237	Instructions - Parts

Models

Part	Purge Rod Diameter in. (mm)	Orifice Size in. (mm)	Handle Type
257999	0.250 (6.35)	0.031 (0.79)	Handheld
24C932	0.250 (6.35)	0.031 (0.79)	Auto

Orifice Flow Area Ratio Chart

In general, flow area ratio should be equal to material ratio but will be influenced by material viscosity. The ideal flow area ratio is dependent on flow rates, material viscosity, and material ratio. Choose the correct size orifices to equalize fluid pressures at the proportioner.

Available Orifice Flow Area Ratios																	Flowrate Increases as Diameter Increases=>
Dia-meter	0.016	0.020	0.024	0.028	0.031	0.035	0.039	0.042	0.047	0.052	0.055	0.060	0.063	0.067	0.073	0.086	
0.016	1.0	1.6	2.3	3.1	3.8	4.8	5.9	6.9	8.6	10.6	11.8	14.1	15.5	17.5	20.8	28.9	
0.020	1.6	1.0	1.4	2.0	2.4	3.1	3.8	4.4	5.5	6.8	7.6	9.0	9.9	11.2	13.3	18.5	
0.024	2.3	1.4	1.0	1.4	1.7	2.1	2.6	3.1	3.8	4.7	5.3	6.3	6.9	7.8	9.3	12.8	
0.028	3.1	2.0	1.4	1.0	1.2	1.6	1.9	2.3	2.8	3.4	3.9	4.6	5.1	5.7	6.8	9.4	
0.031	3.8	2.4	1.7	1.2	1.0	1.3	1.6	1.8	2.3	2.8	3.1	3.7	4.1	4.7	5.5	7.7	
0.035	4.8	3.1	2.1	1.6	1.3	1.0	1.2	1.4	1.8	2.2	2.5	2.9	3.2	3.7	4.4	6.0	
0.039	5.9	3.8	2.6	1.9	1.6	1.2	1.0	1.2	1.5	1.8	2.0	2.4	2.6	3.0	3.5	4.9	
0.042	6.9	4.4	3.1	2.3	1.8	1.4	1.2	1.0	1.3	1.5	1.7	2.0	2.3	2.5	3.0	4.2	
0.047	8.6	5.5	3.8	2.8	2.3	1.8	1.5	1.3	1.0	1.2	1.4	1.6	1.8	2.0	2.4	3.3	
0.052	10.6	6.8	4.7	3.4	2.8	2.2	1.8	1.5	1.2	1.0	1.1	1.3	1.5	1.7	2.0	2.7	
0.055	11.8	7.6	5.3	3.9	3.1	2.5	2.0	1.7	1.4	1.1	1.0	1.2	1.3	1.5	1.8	2.4	
0.060	14.1	9.0	6.3	4.6	3.7	2.9	2.4	2.0	1.6	1.3	1.2	1.0	1.1	1.2	1.5	2.1	
0.063	15.5	9.9	6.9	5.1	4.1	3.2	2.6	2.3	1.8	1.5	1.3	1.1	1.0	1.1	1.3	1.9	
0.067	17.5	11.2	7.8	5.7	4.7	3.7	3.0	2.5	2.0	1.7	1.5	1.2	1.1	1.0	1.2	1.6	
0.073	20.8	13.3	9.3	6.8	5.5	4.4	3.5	3.0	2.4	2.0	1.8	1.5	1.3	1.2	1.0	1.4	
0.086	28.9	18.5	12.8	9.4	7.7	6.0	4.9	4.2	3.3	2.7	2.4	2.1	1.9	1.6	1.4	1.0	
Flowrate Increases as Diameter Increases =>																	

Fixed Orifice Flowrate Data

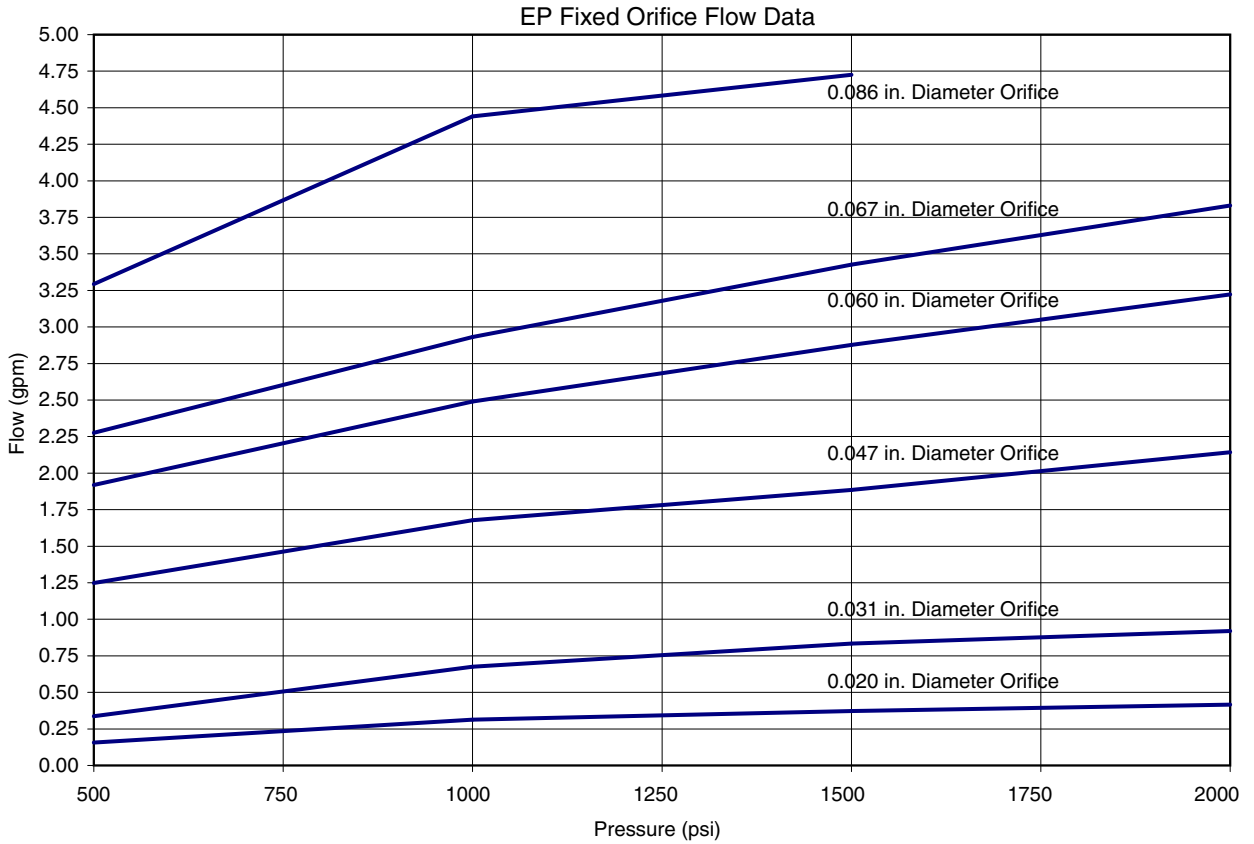

EP Gun Flowrate Data, Tested with 2 lb Foam

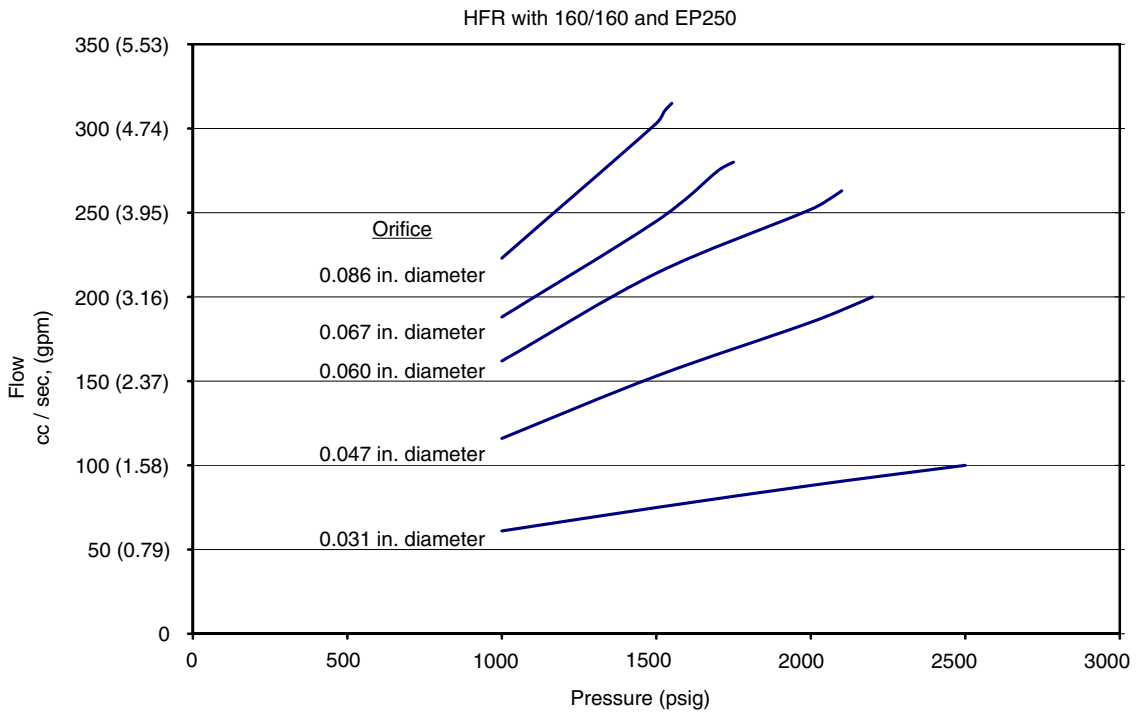

Variable Orifice Flowrate Data

VARIABLE ORIFICE FLOWRATE DATA (1000 PSI)

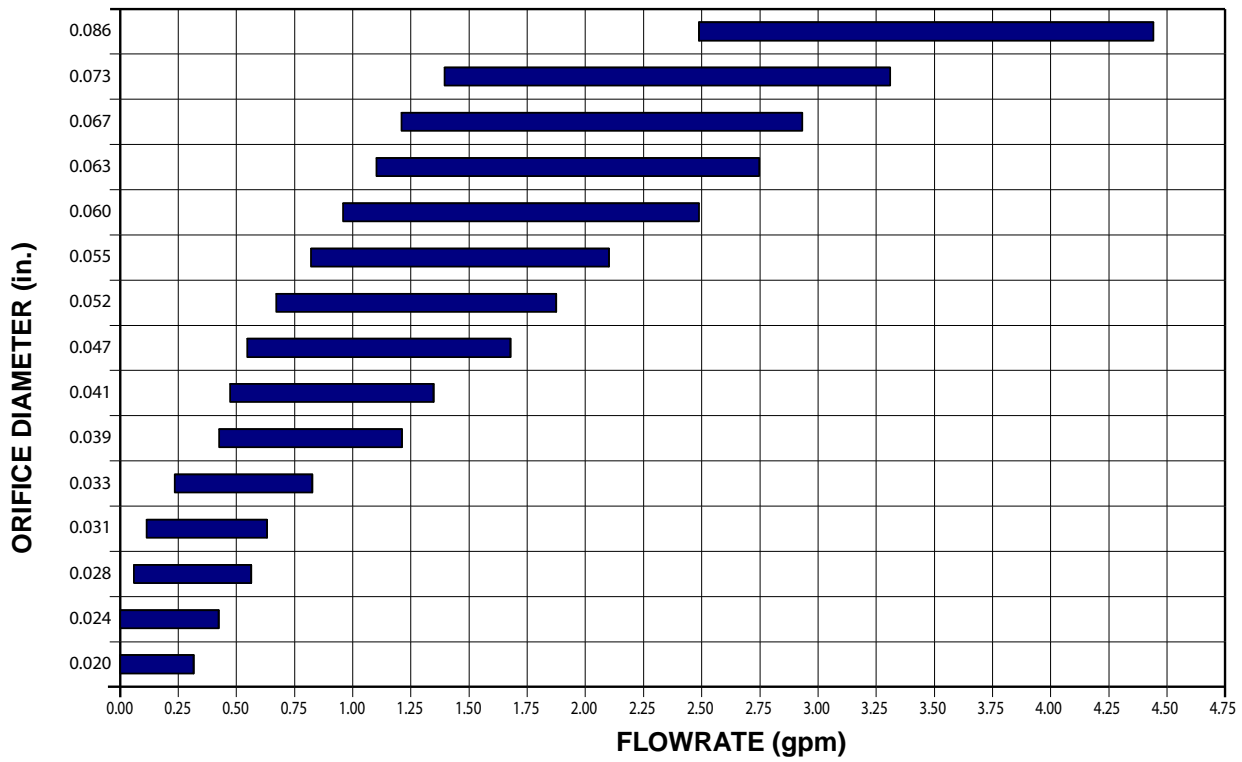

* To calculate flow in lb/min, multiply gpm rate by 10.
Example: 2 gpm x 10 = 20 lb/min.

VARIABLE ORIFICE FLOWRATE DATA (1500 PSI)

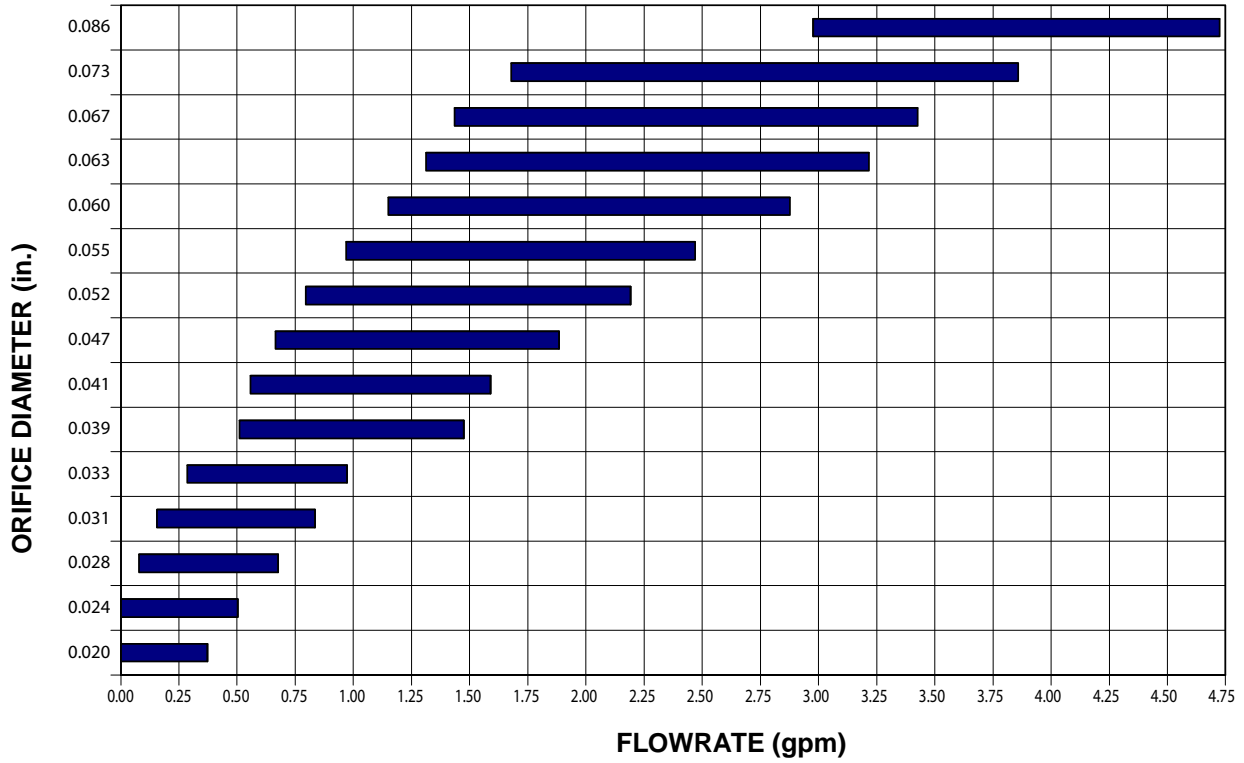

* To calculate flow in lb/min, multiply gpm rate by 10.
Example: 2 gpm x 10 = 20 lb/min.



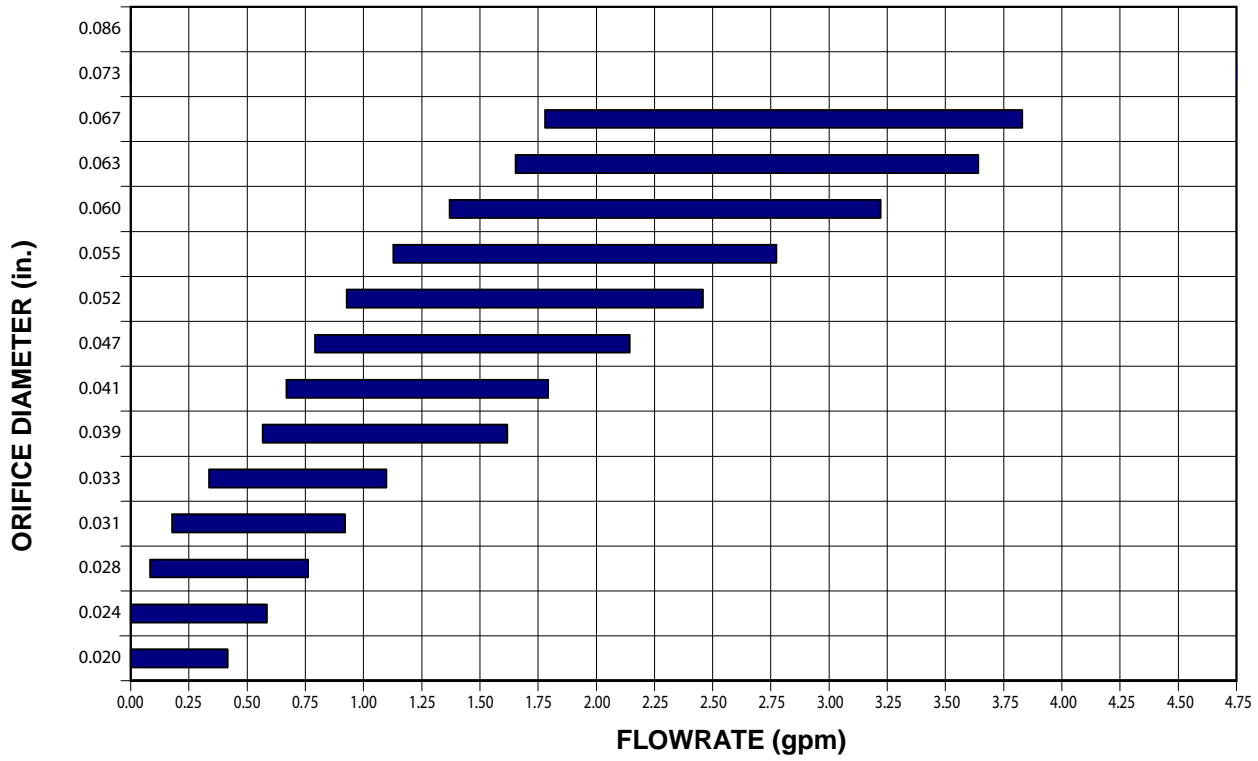

VARIABLE ORIFICE FLOWRATE DATA (2000 PSI)



* To calculate flow in lb/min, multiply gpm rate by 10.
Example: 2 gpm x 10 = 20 lb/min.

Warnings

The following warnings are for the setup, use, grounding, maintenance, and repair of this equipment. The exclamation point symbol alerts you to a general warning and the hazard symbol refers to procedure-specific risk. Refer back to these warnings. Additional, product-specific warnings may be found throughout the body of this manual where applicable.

 WARNING	
	<p>TOXIC FLUID OR FUMES HAZARD</p> <p>Toxic fluids or fumes can cause serious injury or death if splashed in the eyes or on skin, inhaled or swallowed.</p> <ul style="list-style-type: none"> • Read Safety Data Sheet (SDS) for handling instructions and to know the specific hazards of the fluids you are using, including the effects of long-term exposure. • When spraying, servicing equipment, or when in the work area, always keep work area well ventilated and always wear appropriate personal protective equipment. See Personal Protective Equipment warnings in this manual. • Store hazardous fluid in approved containers, and dispose of it according to applicable guidelines.
	<p>PERSONAL PROTECTIVE EQUIPMENT</p> <p>Always wear appropriate personal protective equipment and cover all skin when spraying, servicing equipment, or when in the work area. Protective equipment helps prevent serious injury, including long-term exposure; inhalation of toxic fumes, mists or vapors; allergic reaction; burns; eye injury and hearing loss. This protective equipment includes but is not limited to:</p> <ul style="list-style-type: none"> • A properly fitting respirator, which may include a supplied-air respirator, chemically impermeable gloves, protective clothing and foot coverings as recommended by the fluid manufacturer and local regulatory authority. • Protective eyewear and hearing protection.
	<p>SKIN INJECTION HAZARD</p> <p>High-pressure fluid from dispensing device, hose leaks, or ruptured components will pierce skin. This may look like just a cut, but it is a serious injury that can result in amputation. Get immediate surgical treatment.</p> <ul style="list-style-type: none"> • Engage trigger lock when not dispensing. • Do not point dispensing device at anyone or at any part of the body. • Do not put your hand over the fluid outlet. • Do not stop or deflect leaks with your hand, body, glove, or rag. • Follow the Pressure Relief Procedure when you stop dispensing and before cleaning, checking, or servicing equipment. • Tighten all fluid connections before operating the equipment. • Check hoses and couplings daily. Replace worn or damaged parts immediately
	<p>BURN HAZARD</p> <p>Equipment surfaces and fluid that's heated can become very hot during operation. To avoid severe burns:</p> <ul style="list-style-type: none"> • Do not touch hot fluid or equipment.



WARNING



FIRE AND EXPLOSION HAZARD

Flammable fumes, such as solvent and paint fumes, in **work area** can ignite or explode. To help prevent fire and explosion:

- Use equipment only in well ventilated area.
- Eliminate all ignition sources; such as pilot lights, cigarettes, portable electric lamps, and plastic drop cloths (potential static arc).
- Keep work area free of debris, including solvent, rags and gasoline.
- Do not plug or unplug power cords, or turn power or light switches on or off when flammable fumes are present.
- Ground all equipment in the work area. See **Grounding** instructions.
- Use only grounded hoses.
- Hold gun firmly to side of grounded pail when triggering into pail.
- If there is static sparking or you feel a shock, **stop operation immediately**. Do not use equipment until you identify and correct the problem.
- Keep a working fire extinguisher in the work area.



EQUIPMENT MISUSE HAZARD

Misuse can cause death or serious injury.

- Do not operate the unit when fatigued or under the influence of drugs or alcohol.
- Do not exceed the maximum working pressure or temperature rating of the lowest rated system component. See **Technical Data** in all equipment manuals.
- Use fluids and solvents that are compatible with equipment wetted parts. See **Technical Data** in all equipment manuals. Read fluid and solvent manufacturer's warnings. For complete information about your material, request MSDS from distributor or retailer.
- Do not leave the work area while equipment is energized or under pressure. Turn off all equipment and follow the **Pressure Relief Procedure** when equipment is not in use.
- Check equipment daily. Repair or replace worn or damaged parts immediately with genuine manufacturer's replacement parts only.
- Do not alter or modify equipment.
- Use equipment only for its intended purpose. Call your distributor for information.
- Route hoses and cables away from traffic areas, sharp edges, moving parts, and hot surfaces.
- Do not kink or over bend hoses or use hoses to pull equipment.
- Keep children and animals away from work area.
- Comply with all applicable safety regulations.



PRESSURIZED ALUMINUM PARTS HAZARD

Use of fluids that are incompatible with aluminum in pressurized equipment can cause serious chemical reaction and equipment rupture. Failure to follow this warning can result in death, serious injury, or property damage.

- Do not use 1,1,1-trichloroethane, methylene chloride, other halogenated hydrocarbon solvents or fluids containing such solvents.
- Many other fluids may contain chemicals that can react with aluminum. Contact your material supplier for compatibility.

Important Isocyanate (ISO) Information

Isocyanates (ISO) are catalysts used in two component materials.

Isocyanate Conditions





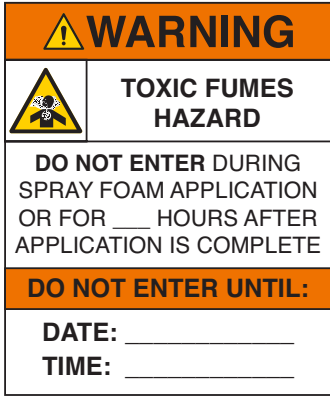

Spraying or dispensing fluids that contain isocyanates creates potentially harmful mists, vapors, and atomized particulates.

- Read and understand the fluid manufacturer's warnings and Safety Data Sheet (SDS) to know specific hazards and precautions related to isocyanates.
- Use of isocyanates involves potentially hazardous procedures. Do not spray with this equipment unless you are trained, qualified, and have read and understood the information in this manual and in the fluid manufacturer's application instructions and SDS.
- Use of incorrectly maintained or mis-adjusted equipment may result in improperly cured material, which could cause off gassing and offensive odors. Equipment must be carefully maintained and adjusted according to instructions in the manual.
- To prevent inhalation of isocyanate mists, vapors and atomized particulates, everyone in the work area must wear appropriate respiratory protection. Always wear a properly fitting respirator, which may include a supplied-air respirator. Ventilate the work area according to instructions in the fluid manufacturer's SDS.
- Avoid all skin contact with isocyanates. Everyone in the work area must wear chemically impermeable gloves, protective clothing and foot coverings as recommended by the fluid manufacturer and local regulatory authority. Follow all fluid manufacturer recommendations, including those regarding handling of contaminated clothing. After spraying, wash hands and face before eating or drinking.
- Hazard from exposure to isocyanates continues after spraying. Anyone without appropriate personal protective equipment must stay out of the work area during application and after application for the time period specified by the fluid manufacturer. Generally this time period is at least 24 hours.
- Warn others who may enter work area of hazard from exposure to isocyanates. Follow the recommendations of the fluid manufacturer and local regulatory authority. Posting a placard such as the following outside the work area is recommended:





For all applications except spray foam

				
--	---	---	---	--

Spraying or dispensing fluids that contain isocyanates creates potentially harmful mists, vapors, and atomized particulates.



- Read and understand the fluid manufacturer's warnings and Safety Data Sheet (SDS) to know specific hazards and precautions related to isocyanates.
- Use of isocyanates involves potentially hazardous procedures. Do not spray with this equipment unless you are trained, qualified, and have read and understood the information in this manual and in the fluid manufacturer's application instructions and SDS.
- Use of incorrectly maintained or mis-adjusted equipment may result in improperly cured material. Equipment must be carefully maintained and adjusted according to instructions in the manual.
- To prevent inhalation of isocyanate mists, vapors, and atomized particulates, everyone in the work area must wear appropriate respiratory protection. Always wear a properly fitting respirator, which may include a supplied-air respirator. Ventilate the work area according to instructions in the fluid manufacturer's SDS.
- Avoid all skin contact with isocyanates. Everyone in the work area must wear chemically impermeable gloves, protective clothing and foot coverings as recommended by the fluid manufacturer and local regulatory authority. Follow all fluid manufacturer recommendations, including those regarding handling of contaminated clothing. After spraying, wash hands and face before eating or drinking.

Material Self-ignition

				
--	---	--	--	--

Some materials may become self-igniting if applied too thick. Read material manufacturer's warnings and Safety Data Sheet (SDS).

Keep Components A and B Separate

				
---	--	---	--	--

Cross-contamination can result in cured material in fluid lines which could cause serious injury or damage equipment. To prevent cross-contamination:

- **Never** interchange component A and component B wetted parts.
- Never use solvent on one side if it has been contaminated from the other side.

Moisture Sensitivity of Isocyanates

Exposure to moisture (such as humidity) will cause ISO to partially cure, forming small, hard, abrasive crystal that become suspended in the fluid. Eventually a film will form on the surface and the ISO will begin to gel, increasing in viscosity.

NOTICE	
Partially cured ISO will reduce performance and the life of all wetted parts.	
<ul style="list-style-type: none"> • Always use a sealed container with a desiccant dryer in the vent, or a nitrogen atmosphere. Never store ISO in an open container. • Keep the ISO pump wet cup or reservoir (if installed) filled with appropriate lubricant. The lubricant creates a barrier between the ISO and the atmosphere. • Use only moisture-proof hoses compatible with ISO. • Never use reclaimed solvents, which may contain moisture. Always keep solvent containers closed when not in use. • Always lubricate threaded parts with an appropriate lubricant when reassembling. 	

NOTE: The amount of film formation and rate of crystallization varies depending on the blend of ISO, the humidity, and the temperature.

Foam Resins with 245 fa Blowing Agents

Some foam blowing agents will froth at temperatures above 90°F (33°C) when not under pressure, especially if agitated. To reduce frothing, minimize preheating in a circulation system.



Changing Materials

NOTICE

Changing the material types used in your equipment requires special attention to avoid equipment damage and downtime.

- When changing materials, flush the equipment multiple times to ensure it is thoroughly clean.
- Always clean the fluid inlet strainers after flushing.
- Check with your material manufacturer for chemical compatibility.
- When changing between epoxies and urethanes or polyureas, disassemble and clean all fluid components and change hoses. Epoxies often have amines on the B (hardener) side. Polyureas often have amines on the B (resin) side.

Throat Seal Liquid

						
Read material MSDS to know specific hazards and precautions related to Throat Seal Liquid.						

Grounding

						
--	---	---	--	--	--	--

Check your local electrical code and proportioner manual for detailed grounding instructions.

Ground the pour gun through connection to a Graco-approved grounded fluid supply hose. Always ground the gun when flushing.

Piston Safety Lock

Engage piston safety lock whenever you stop pouring to avoid accidental triggering and serious injury.

						
--	---	---	---	--	--	--

Engage

To engage piston safety lock, push knob in and turn clockwise. If engaged, gun will not dispense.

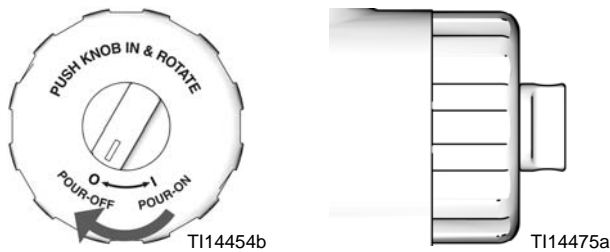

FIG. 1: Piston Safety Lock Engaged

Disengage

To disengage piston safety lock, push knob in and turn counterclockwise until it pops out. There will be a gap between knob and gun body.

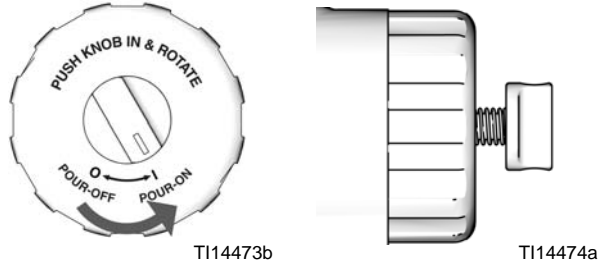
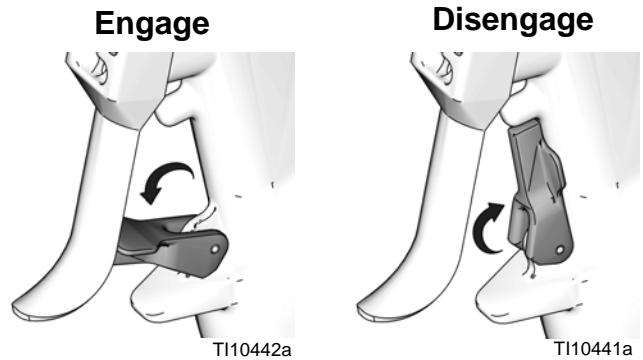

FIG. 2: Piston Safety Lock Disengaged

Trigger Lock

Engage trigger lock whenever you stop pouring to avoid accidental triggering. Must be used with piston safety lock.



Loss of Air Pressure



Purge rod actuation is controlled by air pressure. In event of loss of air pressure, the purge rod will remain retracted, the impingement ports will remain open, and the gun will continue to pour. To stop pouring, do one of the following:

- Engage piston safety lock, see **Piston Safety Lock** section
- Close fluid valves A and B, see FIG. 3

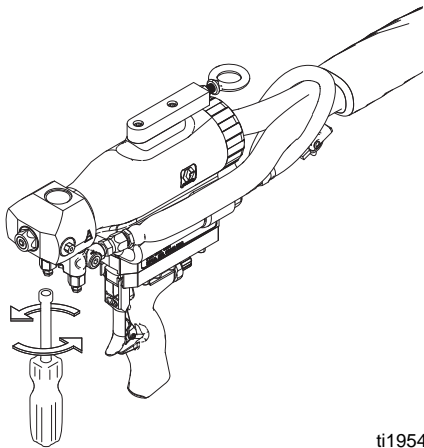

ti19549a

FIG. 3

Hook Support

If necessary, use the hook support located on the top of the gun to support the weight of the gun. Connect a strong rope or chain able to support the weight of the gun to the hook, then connect the other end to a support. This will enable the user to use the gun without having to support the weight of the gun.

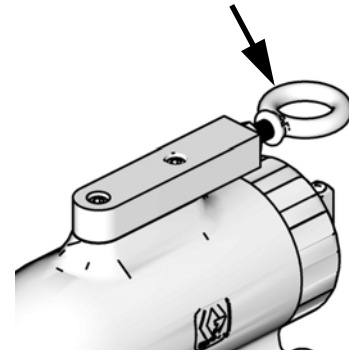

TI14450a1

Component Identification

See **Parts** on page 42 for part numbers and further component identification.

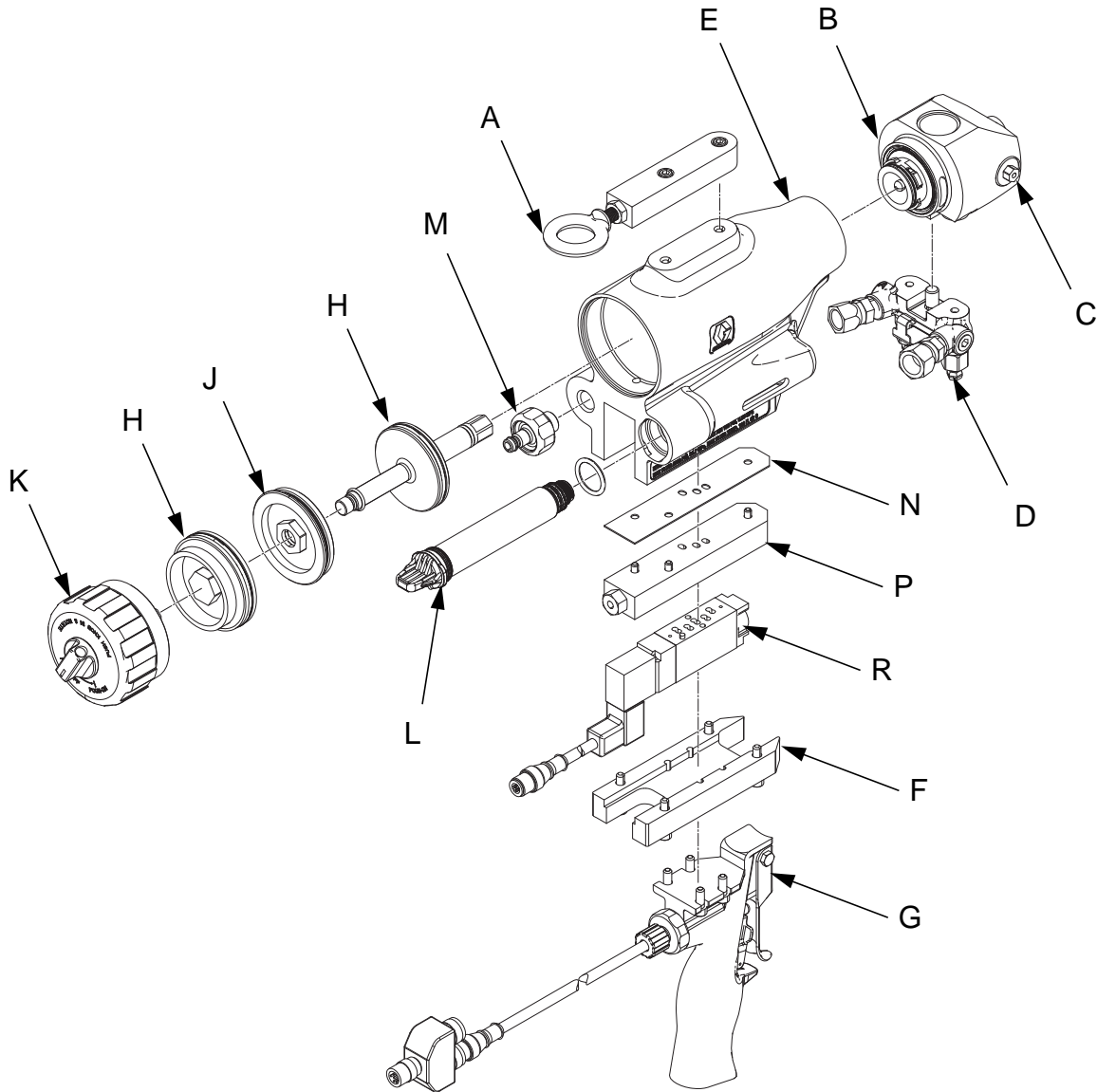

ti19550a

FIG. 4

Key:

- | | |
|--------------------------------------|---------------------------------|
| A Hook Support | H Dual Pistons |
| B Fluid Housing | J Bulkhead |
| C Orifice | K Piston Safety Lock |
| D Fluid Manifold | L Cartridge |
| E Air Cylinder, Gun Body | M Airline Fitting |
| F Mounting Plate | N Solenoid Valve Gasket |
| G Electric Trigger Handle (optional) | P Solenoid Valve Mounting Plate |
| | R Solenoid Valve |

Cutaway View

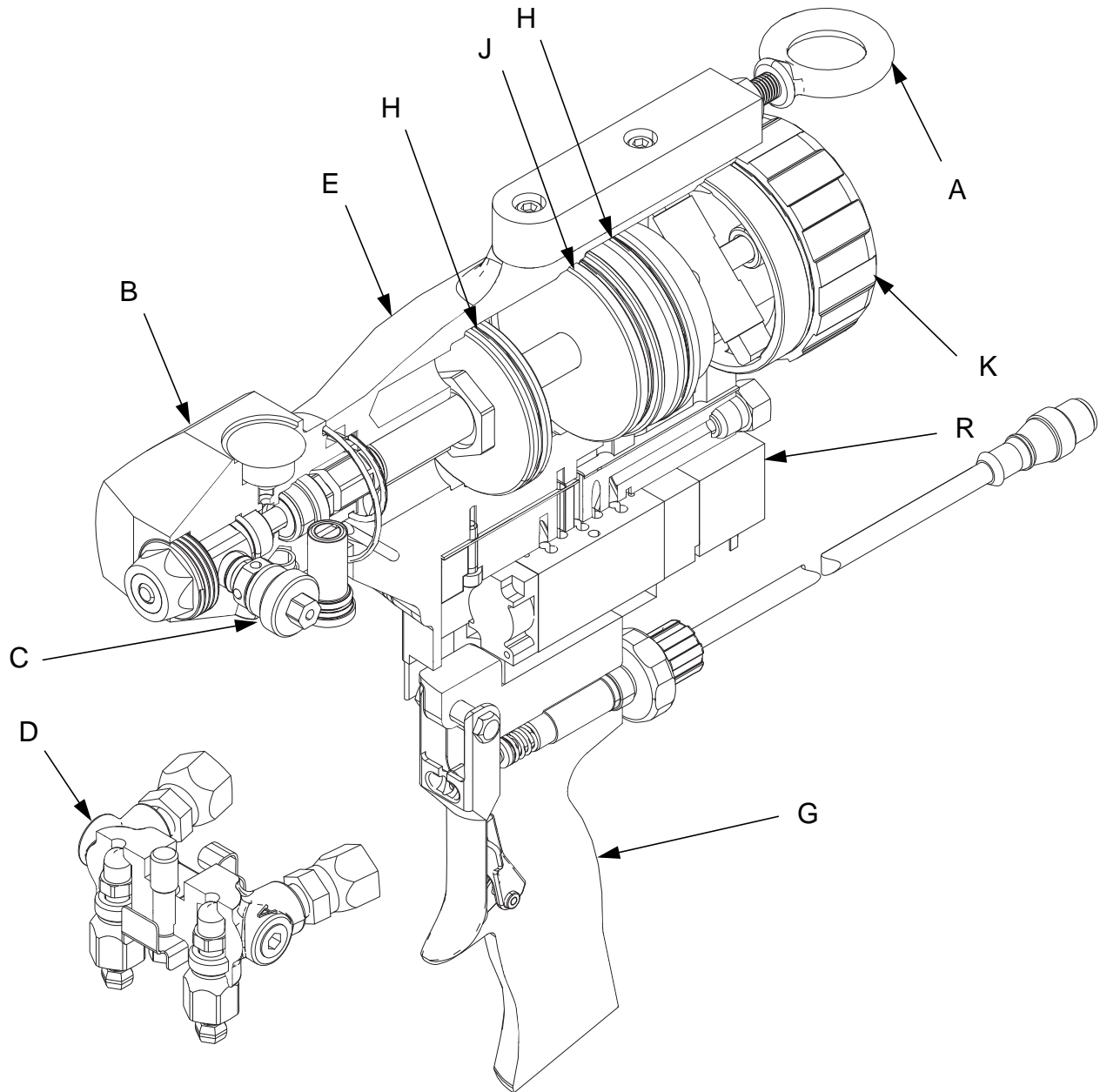

ti19551a

Theory of Operation

Gun Triggered (Fluid Pouring)

Purge rod retracts, opening the impingement ports and allowing fluid to mix and flow through the nozzle.

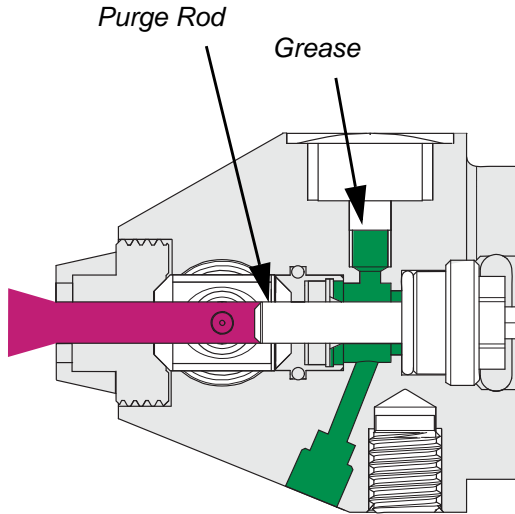

Side View

ti19552a

Gun Detriggered

Purge rod extends, closing the impingement ports and stopping fluid flow.

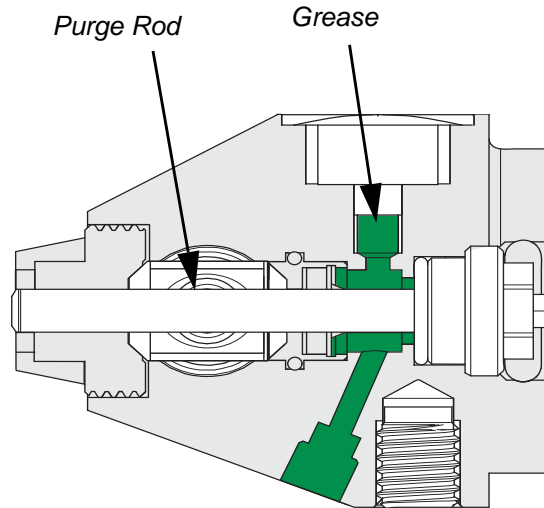

Side View

ti19553a

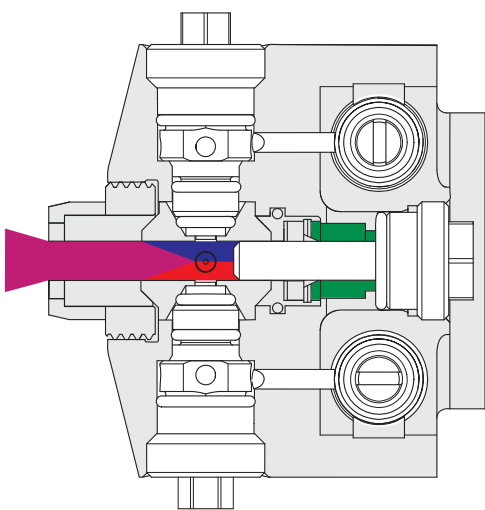

Top View

ti19554a

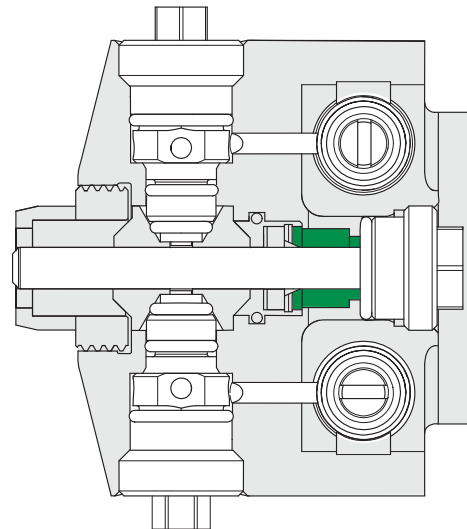

Top View

ti19555a

Setup

Perform this setup procedure to get the pour gun ready for operation.

1. Close fluid valves A and B.

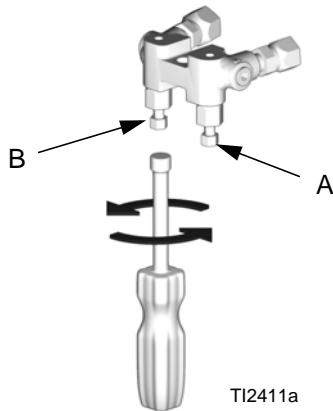
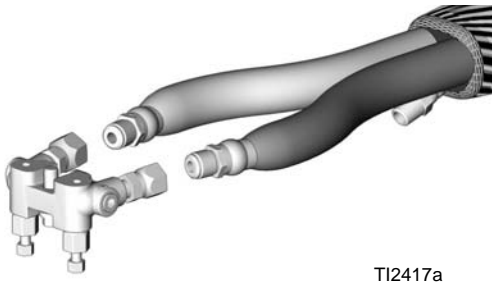

FIG. 5

2. Connect A and B fluid hoses to fluid manifold.



3. Engage piston safety lock. See page 14.
4. Connect gun air whip hose (AA) and air valve (AB) to main air hose. See FIG. 6. Verify air valve is closed.
5. Assemble fluid manifold (AD) to gun by hand then use 5/16 in. nut driver to torque bolt to 20-30 in-lb (2.26-3.39 N•m). See FIG. 6.

6. Connect gun air whip hose (AA) to air quick coupler (AC). Turn on air. Open air valve (AB). See FIG. 6.

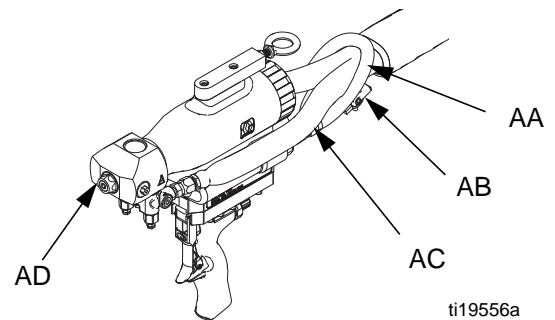

FIG. 6

7. Connect signal cable to solenoid valve.
8. **Models with a handle**, connect signal cable to handle.
9. Disengage piston safety lock. See page 14.

<p>In the following step, do not point gun at yourself. If necessary, use a mirror to verify purge rod travel. Pointing gun at yourself or someone else can lead to accidentally spraying yourself or someone else with fluid. If the purge rod was not correctly installed, purge rod can shoot out of the barrel when gun is actuated and can cause severe injury.</p>						

10. Verify fluid valves are closed, see FIG. 5, then trigger gun to check for full purge rod travel.

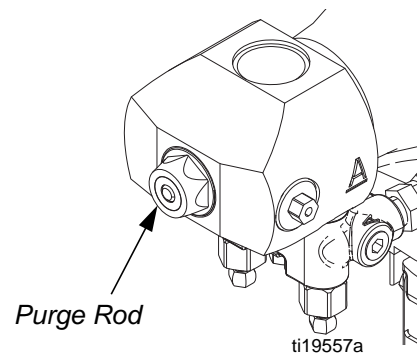
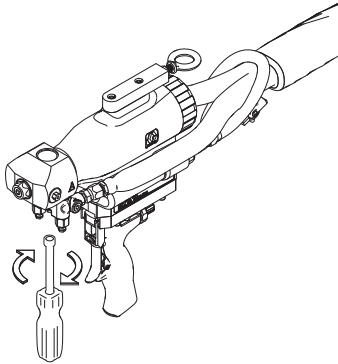

FIG. 7

11. Engage piston safety lock. See page 14.
12. Turn on proportioner. See proportioner manual.
13. Open fluid valves A and B.



ti19558a

FIG. 8

14. Disengage piston safety lock. See page 14.



15. Perform a test pour into a waste container. Adjust pressure and temperature to get desired results, see proportioner manual. Also, see **Adjust Orifices**.

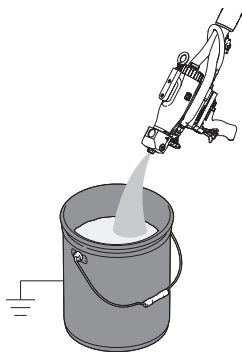

ti19559a

FIG. 9

Adjust Orifices

In order to balance pressures between the A component and B component the needle in each orifice may need to be adjusted. Be sure that all necessary adjustments to the proportioner are made prior to adjusting the orifices, see proportioner manual.

If after adjusting pressures neither orifice can achieve the desired pressure both orifices should be replaced with a larger or smaller size. Note that a smaller orifice will provide higher pressure and a larger orifice will provide lower pressure.

If after attempting to balance pressures the pressure difference is over 500 psi one orifice should be replaced with a different size. If that is the case, adjust the needle in each orifice all the way open (counter-clockwise) and observe the pressures. The orifice whose pressure is farthest from the desired pressure should be replaced. Note that a smaller orifice will provide higher pressure and a larger orifice will provide lower pressure.

1. Insert a 5/64 in. hex key (supplied) into the opening in the hex on the orifice.
2. **In order to increase the pressure**, turn the needle clockwise.

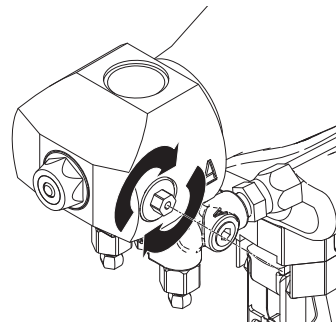

ti19561a

In order to decrease the pressure, turn the needle counter-clockwise.

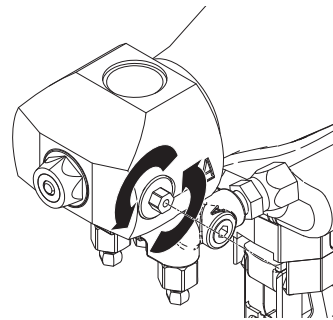

ti19560a

Optional Hose Position

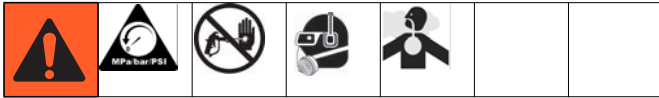

As shipped, fluid inlet swivel fittings point to rear of the gun. If desired, use the following procedure to make the fluid inlet swivel fittings point downward.

NOTICE

To prevent cross-contamination of gun's wetted parts, do not interchange A component (isocyanate) and B component (resin) parts.

1. Follow **Pressure Relief Procedure**, page 24.
2. Disconnect air quick coupler. Use hex nut driver to remove fluid manifold (AD).

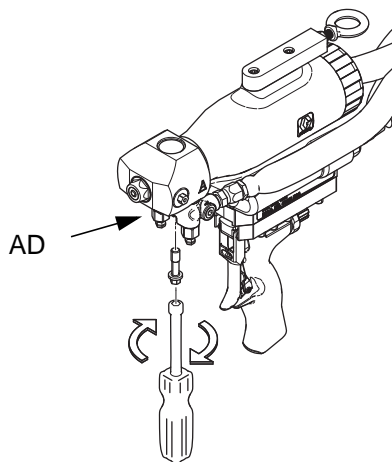

ti19562a

3. Disconnect signal cable.
4. Place a cap over the end of each hose. Disconnect fluid hoses from inlet swivels (AE). Remove plugs from optional inlets (AG).

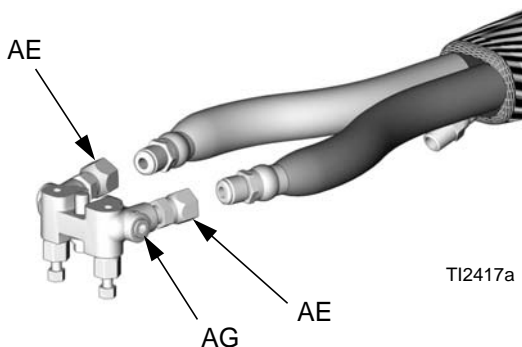

TI2417a

Fig. 10

5. Apply thread sealant to plugs (AH), elbows (AJ), and male threads of swivels (AE). Install elbows (AJ) in optional inlets, facing down. See FIG. 11. Install swivels in elbows. Be sure to install the A swivel in the A side. Install plugs (AH) where swivels had been. Torque all parts to 235-245 in-lb (26.6-27.7 N•m).

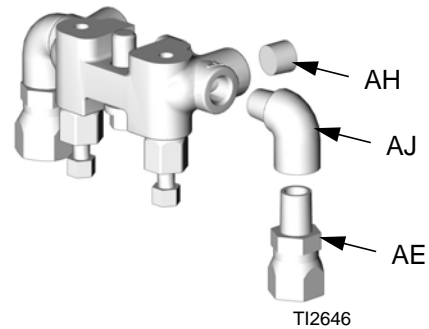

TI2646

Fig. 11

6. Connect the A hose to the A swivel and the B hose to the B swivel.
7. Attach fluid manifold (AD) to gun. Torque fluid manifold bolt to 20-30 in-lb (2.26-3.39 N•m).
8. Connect air quick coupler (AC).

Pressure Relief Procedure



1. Engage piston safety lock. See page 14.

NOTE: Air supply is required for purge rod actuation. Do not disconnect gun air supply until fluid pressure is relieved.

2. Close fluid valves A and B. Leave air valve (AB) open.

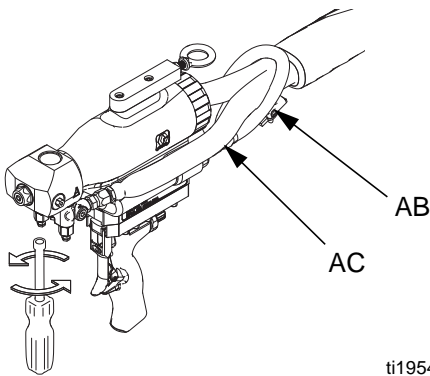

ti19549a

FIG. 12

3. Disengage piston safety lock. See page 14.
4. Trigger gun onto cardboard or into waste container to relieve pressure.

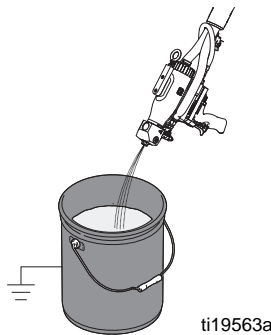

ti19563a

FIG. 13

5. Disconnect air quick coupler (AC). See FIG. 12.
6. Engage piston safety lock. See page 14.

7. Relieve system pressure. See Pressure Relief Procedure in proportioner manual.

8. Ensure fluid valves are closed then remove fluid manifold.

9. Place the fluid manifold over waste containers, facing away from you.



10. Very slowly open the fluid valves. Under high pressure, fluid will spray sideways from the fluid ports.

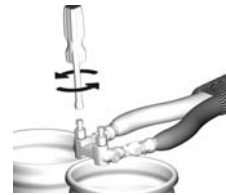

T12484a

Shutdown



Short Term Shutdown

Perform Short Term Shutdown procedure if gun will not be used for more than one hour.

1. Perform **Pressure Relief Procedure** on page 24.
2. Engage piston safety lock.
3. Trigger gun to retract purge rod.
4. While purge rod is retracted, remove any material build-up on front poor tip and front packing.

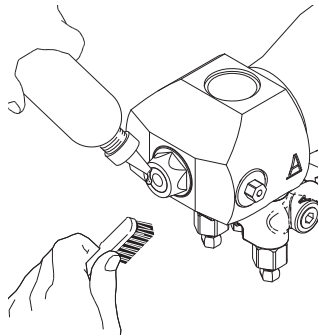

ti19564a

5. While purge rod is retracted, spray Throat Seal Lubricant (TSL) into the front nose.
6. Trigger gun five times in order to ensure material does not build up on purge rod.
7. Detrigger gun and leave the air on.
8. Perform **Grease the Gun** on page 26.

Long Term Shutdown

Perform Long Term Shutdown procedure if gun will not be used for more than 48 hours.

1. Perform **Short Term Shutdown**.
2. **Flush Gun**, see page 27.

Maintenance

Procedure	Schedule
Grease the Gun, page 26	Daily
Replace Mix Chamber and Front Seal, see page 31	Every 2-4 Weeks
Clean Check Valves, page 29	Monthly
Clean Outside of Gun, page 28	As Needed
Clean Breather Plug, page 28	As Needed
Clean Fluid Manifold, page 28	As Needed
Clean Fluid Housing Passages, page 30	As Needed
Clean Orifice, page 31	As Needed

Supplied Tool Kit

See **Parts** on page 42 for tool illustrations.

- Hex Nut Driver; 5/16
- Screwdriver; 1/8 blade
- Impingement Port Drill Bit; various sizes depending on port size
- 117661 Pin Vise; dual reversible chucks, see FIG. 14
- 117773 Fusion[®] grease
- 117792 Grease Gun
- 100633 Allen Wrench; 5/32



FIG. 14: Pin Vise

Lubrication

See **Accessories** on page 55 to order lubricant. Liberally lubricate all o-rings, seals, and threads.

NOTICE
Use only Throat Seal Liquid on the o-rings, seals, and threads of the cartridge. Fusion grease or other petroleum-based or vegetable-based lubricants will cause cartridge o-rings and seals to swell and stick.

Grease the Gun



1. Perform pressure relief procedure. See **Pressure Relief Procedure** on page 24.
2. Perform short term shutdown procedure. See **Short Term Shutdown** on page 25.
3. Use a 5/32 in. allen key to remove the weep plug.

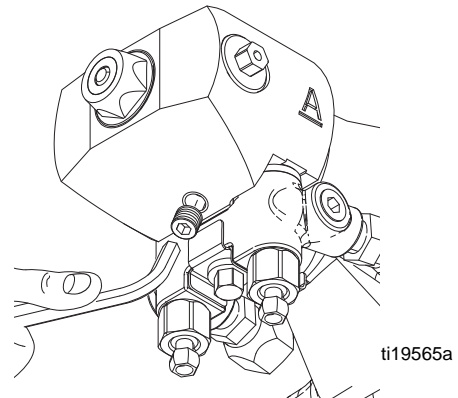

4. Use a grease gun with the required synthetic grease, part 117773, to purge the gun body until grease exits the weep hole without evidence of foreign material.

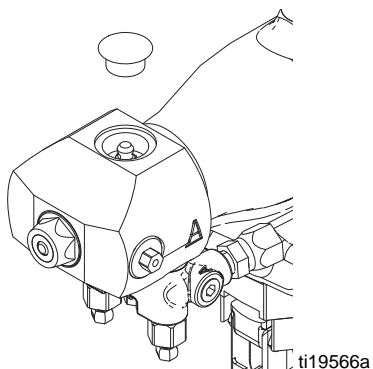

5. Use a 5/32 in. allen key to install the weep plug.

Flush Gun

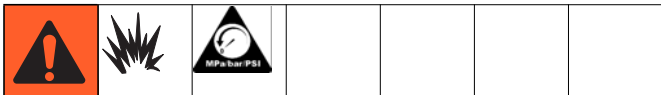

1. Follow **Pressure Relief Procedure**, page 24.
2. Remove fluid manifold (AD).

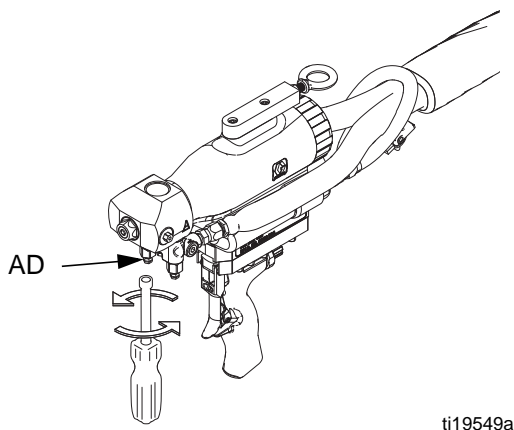

FIG. 15

3. Disconnect signal cable.

4. Install flush hoses to flush manifold 15B817. See FIG. 16. Install flush manifold onto gun. Torque flush manifold bolt to 20-30 in-lb (2.26-3.39 N•m).

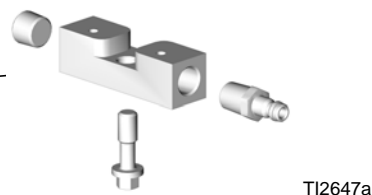

FIG. 16: Flush Manifold

5. Holding a metal part of flush manifold firmly to side of grounded pail and flush with compatible solvent into a grounded metal pail. See wetted parts info in **Technical Data**, page 57. Use lowest possible fluid pressure when flushing.
6. Follow **Pressure Relief Procedure**, page 24.

NOTE: For a more thorough flush, solvent flush kits are available as an accessory. See **Accessories** on page 55.

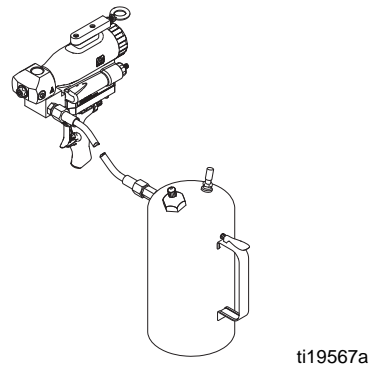
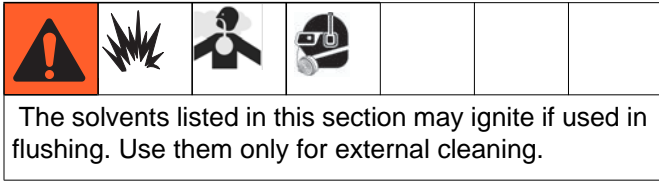

FIG. 17: 248139, 1 qt (0.95 liter) Solvent Cup

7. Remove flush hoses from flush manifold. Remove flush manifold from gun.
8. Remove Recirculation Block 15C850 from fluid manifold.
9. Connect fluid manifold to gun. Torque fluid manifold bolt to 20-30 in-lb (2.26-3.39 N•m).
10. Connect signal cable.

Clean Outside of Gun



Wipe the outside of the gun with a compatible solvent. See materials of construction info in **Technical Data**, page 57. Use N-Methylpyrrolidone (NMP), Dynasolve CU-6, Dzolv, or an equivalent solvent to soften cured material. Applying a light coat of lubricant will make future cleaning easier.

Clean Breather Plug

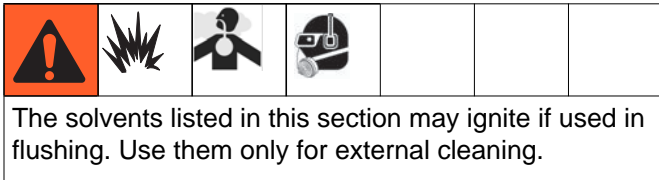

Remove and clean breather plug with compatible solvent. See materials of construction info in **Technical Data**, page 57. The breather plug is part of the solenoid manifold assembly (30). See FIG. 18. Use N-Methylpyrrolidone (NMP), Dynasolve CU-6, Dzolv, or an equivalent to soften cured material. Applying a light coat of lubricant will make future cleaning easier. Torque breather plug to 30-40 in-lb (3.89-4.82 N•m).

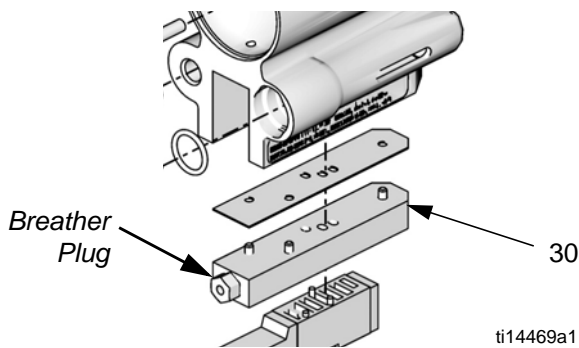

FIG. 18: Breather Plug

Clean Fluid Manifold



Fluid Manifold Fluid Ports

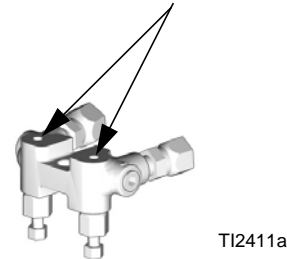
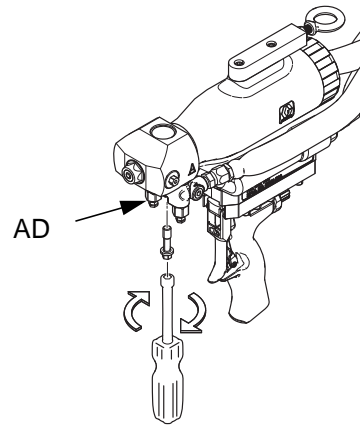

FIG. 19

1. Follow **Pressure Relief Procedure**.
2. Use 5/16 in. hex nut driver to remove fluid manifold (AD).



3. Disconnect signal cable.
4. Clean fluid manifold fluid ports with compatible solvent and brush whenever removed from gun. See materials of construction info in **Technical Data**, page 57. To prevent damaging the internal sealing surfaces, do not use brush to clean inside diameter of fluid ports. Fill fluid ports with grease if left exposed, to seal out moisture. See FIG. 19.
5. Install fluid manifold. Torque fluid manifold bolt to 20-30 in-lb (2.26-3.39 N•m).
6. Connect signal cable.

Clean Check Valves



1. Follow **Pressure Relief Procedure**, page 24.
2. **Flush Gun**, page 27.
3. Disconnect air quick coupler (AC). Use hex nut driver to remove fluid manifold (AD).

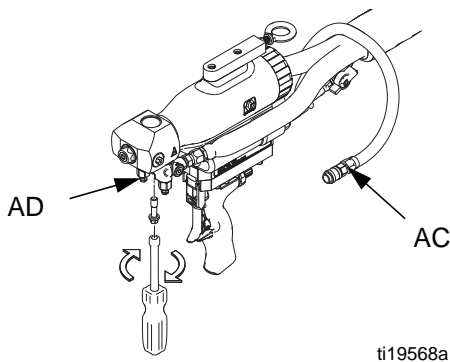

4. Disconnect signal cable.
5. Clean and inspect check valve mating surfaces and fluid ports. See **Clean Fluid Manifold** on page 28.

NOTICE

To prevent cross-contamination of the check valves, do not interchange A component and B component parts. The A component check valve is marked with an A.

6. Use flat tip screwdriver to pry out check valves at notch.

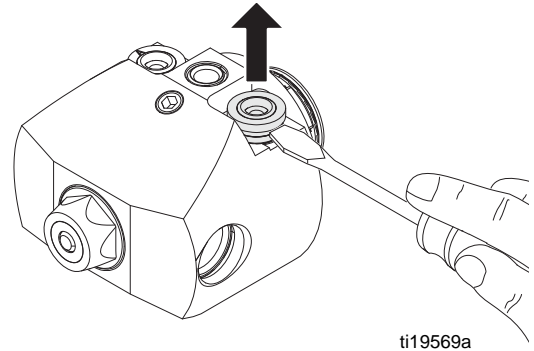

Damaged check valve o-rings may result in external leakage. Replace o-rings if worn or damaged.

7. Press on ball (BC) to test check valve for proper movement and spring action. Replace check valve assembly if necessary.
8. Slide filter (BD) off. Clean and inspect parts. Thoroughly inspect o-rings (BE, BG). If necessary, remove screw (BA) and disassemble check valve.

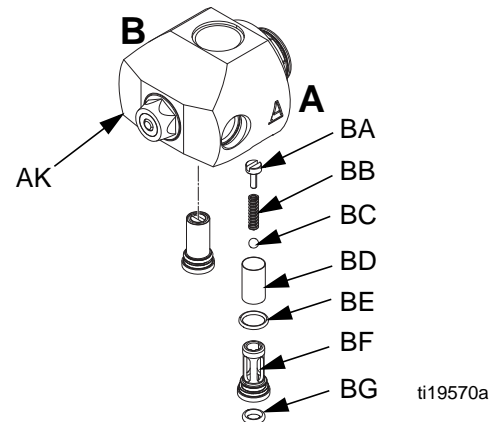
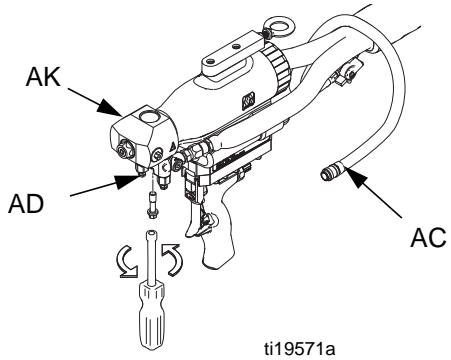

FIG. 20

9. Liberally lubricate o-rings (BE, BG). Reassemble check valves. Screw (BA) should be flush with check valve housing surface (within 1/16 in. or 1.5 mm).
10. Install check valves into fluid housing (AK).

- Use hex nut driver to install fluid manifold (AD). Torque fluid manifold bolt to 20-30 in-lb (2.26-3.39 N•m). Connect air quick coupler (AC).



- Connect signal cable.

Clean Fluid Housing Passages



If necessary, use drill bits to clean the passages in the fluid housing and gun body. See **Drill Bit Kits**, page 53.

- Follow **Pressure Relief Procedure** on page 24.

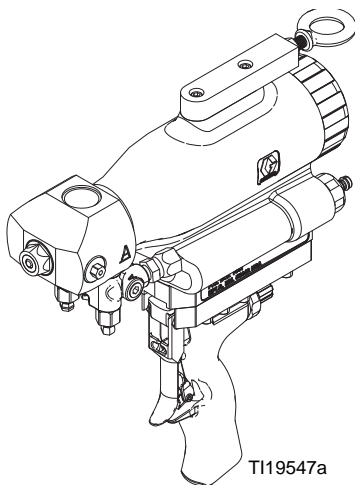

FIG. 21

- Use 5/16 in. nut driver (supplied) to remove orifices (C). See FIG. 4 on page 18.

NOTICE

To prevent cross-contamination of the orifices do not interchange A component and B component parts. The A component orifice is marked with an A.

- Remove Front End**, see page 33.
- Remove all items from front end to enable cleaning of passages. See **Disassemble Front End** on page 34.
- Use appropriate drill bits to clean fluid housing passages. See FIG. 22. See **Drill Bit Kits**, page 53.

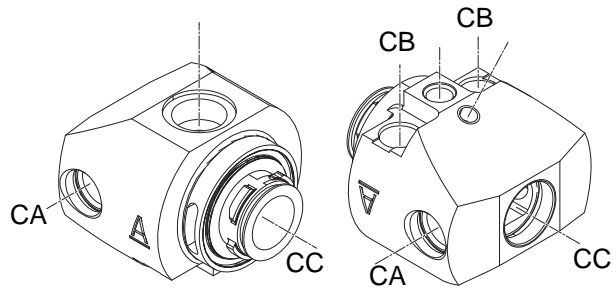

Key:

- CA Orifice Passage
- CB Fluid Inlets
(on bottom of fluid housing)
- CC Nozzle

Cleanout Tool:

- 27/64" drill bit
- 1/8" drill bit
- 1/4" drill bit

FIG. 22: Fluid Housing Passages

- See **Assemble Front End** on page 34.
- Attach Front End**, see page 35.
- Install orifices. Torque to 20-30 in-lb (2.26-3.39 N•m).

Clean Orifice



1. Follow **Pressure Relief Procedure** on page 24.
2. Use 5/16 in. nut driver (supplied) to remove orifices (C). See FIG. 4 on page 18.

NOTICE

To prevent cross-contamination of the orifices do not interchange A component and B component parts. The A component orifice is marked with an A.

NOTE: The cap is held in place with reverse threads.

3. Remove cap (25f) from orifice (25g).

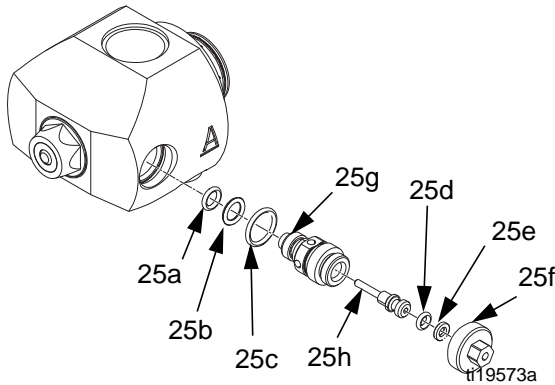

4. Remove needle (25h) from orifice. Thoroughly inspect all o-rings and replace if necessary.
5. If necessary, use drill bit that is the same size as the orifice to drill out the orifice. Orifice size is marked on the orifice.
6. Use Fusion grease to liberally lubricate all o-rings.
7. Reassemble in reverse order. Torque orifice body into orifice cap to 60-70 in-lb (6.78-7.91 N•m). Torque orifices into fluid housing to 20-30 in-lb (2.26-3.39 N•m).

NOTE: Back-up ring (25e) is placed behind the o-ring (25d) on the needle.

Replace Mix Chamber and Front Seal

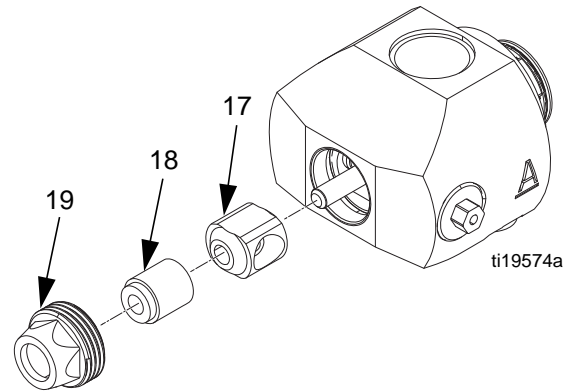

1. Follow **Pressure Relief Procedure** on page 24.
2. Use 5/16 in. nut driver (supplied) to remove orifices (25, 26, 27).
3. Use a 3/4 in. wrench to remove front pour tip (19).
4. Connect air quick coupler (AC).
5. Press and release trigger to push out the mix chamber (17) and front seal (18) and discard.
6. Disconnect air quick coupler (AC).
7. Install new mix chamber and front seal.
8. Replace front pour tip and torque to 60-70 in-lb (6.78-7.91 N•m).

NOTICE

To prevent cross-contamination of the orifices do not interchange A component and B component parts. The A component orifice is marked with an A.

9. Replace orifices. Torque to 20-30 in-lb (2.26-3.39 N•m).

Repair

Tools Required

Tools required to complete some gun repair procedures:

- 15/16 in. wrench
- flat head screwdriver (supplied)
- 5/16 hex nut driver (supplied)
- 1/2 in. deep well socket
- 3/4 in. deep well socket
- 5/64 in. allen wrench (supplied)
- 9/64 in. allen wrench
- 5/32 in. allen wrench
- Phillips screwdriver

Lubrication

See **Accessories** on page 55 to order lubricant. Liberally lubricate all o-rings, seals, and threads.

NOTICE

Use only Throat Seal Liquid on the o-rings, seals, and threads of the cartridge. Fusion grease or other petroleum-based or vegetable-based lubricants will cause cartridge o-rings and seals to swell and stick.

Replace Cartridge



The cartridge is necessary for proper operation of the gun. Replacement of the cartridge is unnecessary for the lubrication of the purge rod.

Remove Front End



NOTICE

Proper attachment of front end is critical. Do not operate gun if front end is loose or not snug against body. Improper attachment can cause slow leaks.

1. Perform **Pressure Relief Procedure**, page 24.
2. **Flush Gun**, see page 27.
3. Disconnect air quick coupler (AC). Use hex nut driver to remove fluid manifold (AD).

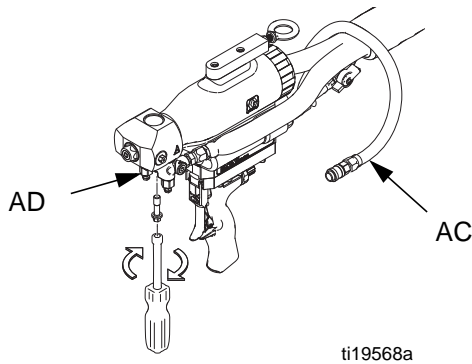

4. Disconnect signal cable.
5. Rotate fluid housing (AK) 45 degrees counterclockwise to disengage fluid housing slots.

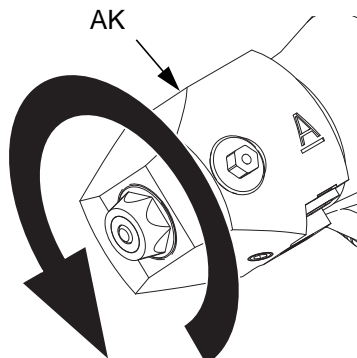

6. Pull fluid housing away from gun body to remove. If fluid housing cannot be removed perform the following steps.
 - a. Attach air quick coupler.
 - b. Pull and release the trigger or press and release the red button on the solenoid valve.
 - c. Remove fluid housing.
 - d. Disconnect air quick coupler.
7. Disengage purge rod from ball socket in piston shaft then remove purge rod.

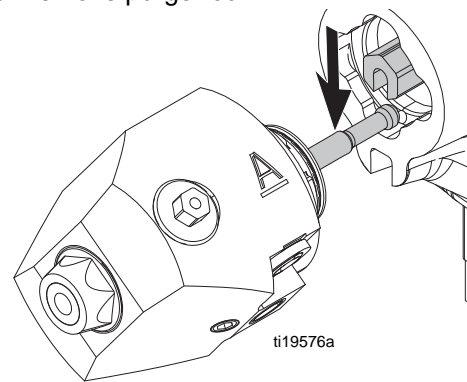

8. Inspect fluid housing o-rings for wear or damage. Replace if necessary.

Disassemble Front End



NOTICE

To prevent cross-contamination of the equipment's wetted parts, **never** interchange component A (isocyanate) and component B (resin) parts. The gun is shipped with the A side on the left. The fluid manifold, fluid housing, side seal assembly, check valve cartridge, and mix chamber are marked on the A side.

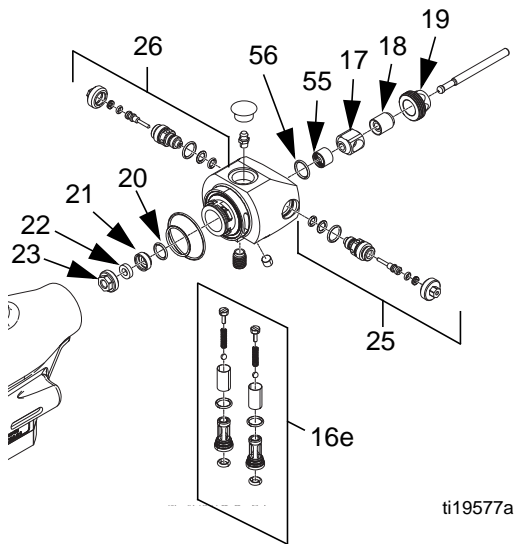

ti19577a

1. **Remove Front End**, see page 33.
2. Remove check valve assembly (16e).
3. Remove orifice (25). Repeat for opposite side.
4. Remove pour tip (19).
5. Remove front packing (18), mix module (17), scraper assembly (55), and o-ring (56).
6. Remove rear packing nut (23), seal (22), rear packing housing (21), and o-ring (20).

Assemble Front End



NOTICE

To prevent cross-contamination of the equipment's wetted parts, **never** interchange component A (isocyanate) and component B (resin) parts. The gun is shipped with the A side on the left. The fluid manifold, fluid housing, side seal assembly, check valve cartridge, and mix chamber are marked on the A side.

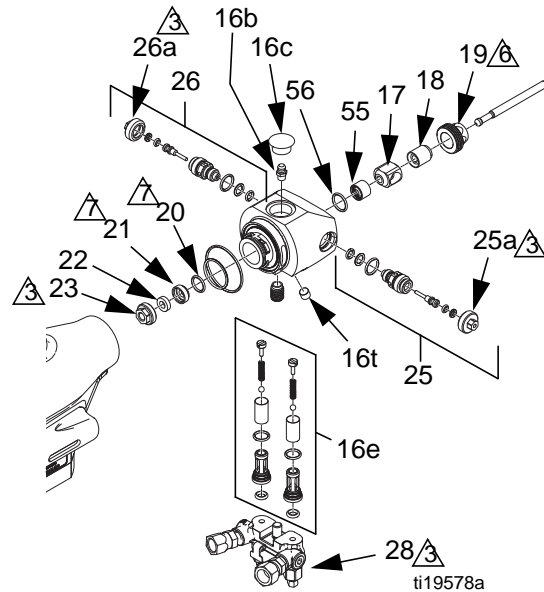

ti19578a

- Torque to 20-30 in-lb (2.26-3.39 N•m)
 - Torque to 60-70 in-lb (6.78-7.91 N•m)
1. Install o-ring (20), rear packing housing (21), seal (22), and rear packing nut (23). Torque rear packing nut to 20-30 in-lb (2.26-3.39 N•m).
 2. Install o-ring (56), scraper assembly (55), mix module (17), and then front packing (18).
 3. Install pour tip (19) hand-tight.
 4. Install purge rod into front of fluid housing. Press purge rod through housing until 3/4 in. of ball socket end of purge rod extends out of housing as shown in FIG. 23.

5. Install check valve assembly. See **Clean Check Valves** on page 29 for detailed assembly instructions.
6. Install orifice components (25). Install orifice cap (25a) and torque to 20-30 in-lb (2.26-3.39 N•m). Repeat for opposite side.
7. See **Attach Front End** procedure.

Attach Front End

NOTICE

Proper attachment of front end is critical. Do not operate gun if front end is loose or not snug against body. Improper attachment can cause slow leaks.

1. Engage piston safety lock.
2. Liberally lubricate o-rings and install on fluid housing (AK).
3. Apply thin coat of TSL to purge rod.
4. Install fluid housing onto purge rod.
5. Insert end of purge rod into ball socket in piston shaft.

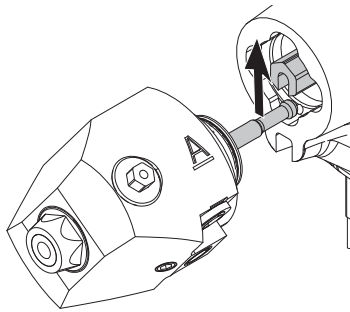

ti19579a

FIG. 23

6. Push fluid housing flush to the gun body. Rotate fluid housing 45 degrees clockwise to engage fluid housing slots.

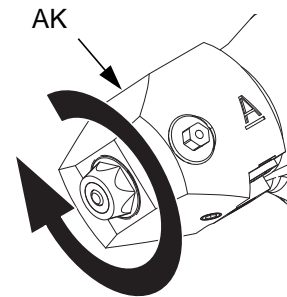

ti19580a

7. Torque pour tip (19) to 60-70 in-lb (6.7-9.1 N•m).
8. Use hex nut driver to install fluid manifold (AD). Torque fluid manifold bolt to 20-30 in-lb (2.26-3.39 N•m). Connect air quick coupler (AC).

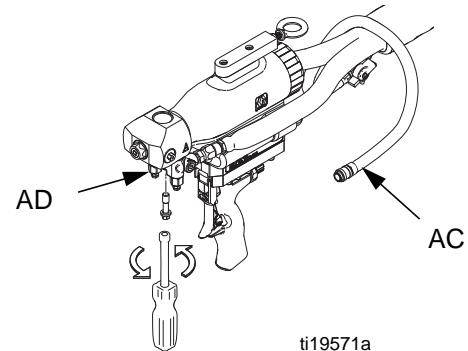

ti19571a

9. Connect signal cable.

Pistons and Bulkhead



User should have piston seals kit 24D312 available before performing this procedure.

1. Follow **Pressure Relief Procedure**, page 24.
2. Use hex nut driver to remove fluid manifold (AD).

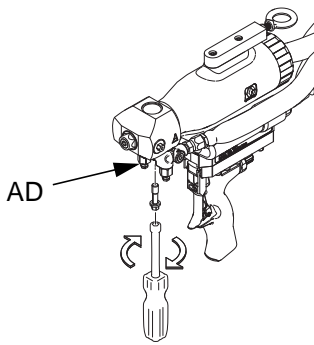

ti19562a

3. Disconnect signal cable.
4. **Remove Front End**, see page 33.
5. Disconnect air quick coupler (AC).

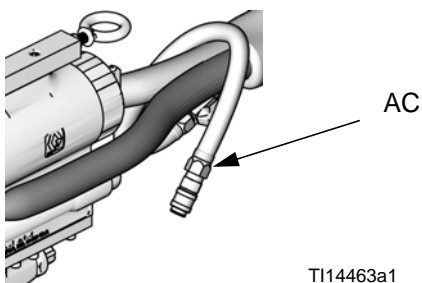

T114463a1

6. Unscrew piston safety lock assembly and remove. Inspect o-ring and replace if necessary.

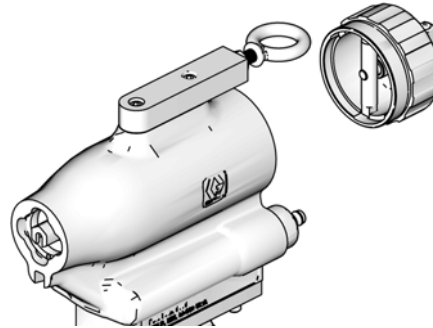

T114465a

7. Place 1/2 in. socket on the piston shaft through the front of the gun body. Entering through the rear of the gun body, place a 3/4 in. socket with extension on the rear piston. Hold piston shaft in place and remove the rear piston. Inspect rear piston o-ring and replace if necessary.

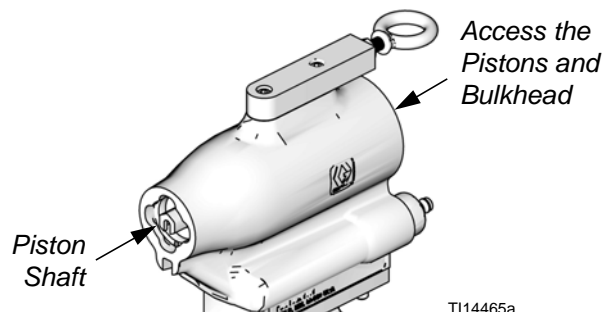

T114465a

8. Entering through the rear of the gun body, place a 3/4 in. socket with extension on the bulkhead. Remove the bulkhead. Inspect bulkhead o-rings and replace as necessary.
9. Push piston shaft towards rear of gun to remove front piston and piston shaft from the gun body.
10. Use a 1/2 in. socket on the piston shaft and 15/16 in. wrench on the front piston to remove front piston from piston shaft.
11. Inspect o-rings. Replace if worn or damaged. Liberally lubricate o-rings then reinstall.
12. Apply medium strength thread locker to threads then install front piston onto piston shaft. Torque to 100-110 in-lb (11.3-12.4 N•m). See **Component Identification** on page 18.
13. Install piston shaft and piston assembly into gun body. See **Component Identification** on page 18.

14. Install bulkhead onto piston shaft. Torque to 100-110 in-lb (11.3-12.4 N•m). See **Component Identification** on page 18.
15. Apply medium strength threadlocker to threads then install rear piston onto piston shaft. Torque to 100-110 in-lb (11.3-12.4 N•m). See **Component Identification** on page 18.
16. Install piston safety lock. See **Component Identification** on page 18.
17. **Attach Front End**, see page 35.
18. Use hex nut driver to install fluid manifold (AD). Torque fluid manifold bolt to 20-30 in-lb (2.26-3.39 N•m). Connect air quick coupler (AC).

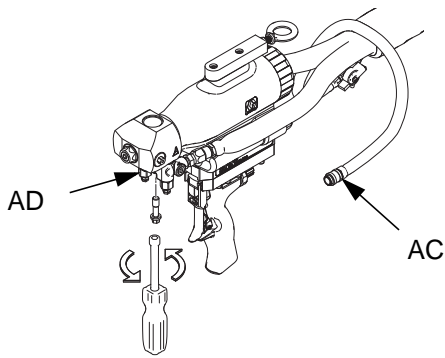

ti19571a

19. Connect signal cable.

Purge Rod



1. **Flush Gun**, page 27.
2. Follow **Pressure Relief Procedure**, page 24.
3. Disconnect air quick coupler (AC). Use hex nut driver to remove fluid manifold (AD).

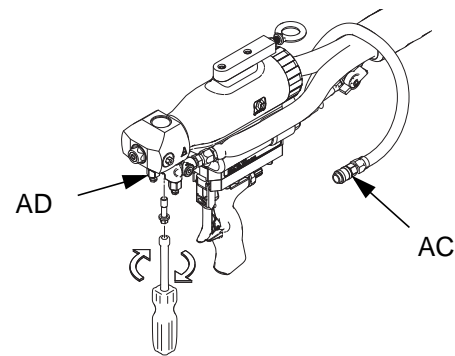

ti19568a

4. Disconnect signal cable.
5. **Remove Front End**, see page 33. Inspect purge rod for wear or damage. Replace if necessary.
6. Use 3/4 in. wrench to loosen front tip. Coat purge rod with TSL then replace purge rod.
7. **Attach Front End**, see page 35.
8. Attach air quick coupler to fully extend purge rod. Tighten front tip to 60-70 in-lb (6.78-7.91 N•m)
9. Install fluid manifold. Torque fluid manifold bolt to 20-30 in-lb (2.26-3.39 N•m).
10. Connect signal cable.

Solenoid Valve

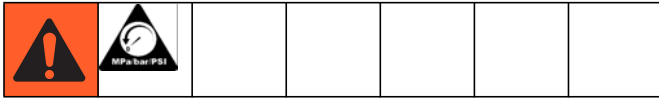



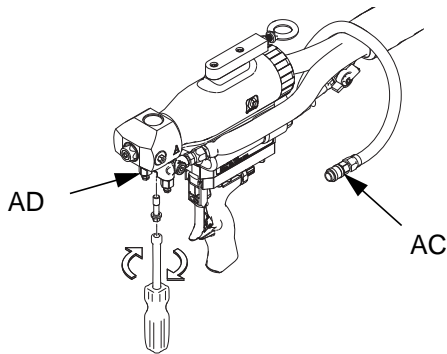

1. Follow **Pressure Relief Procedure** on page 24.
2. Disconnect air quick coupler (AC). Use hex nut driver to remove fluid manifold (AD).



ti19568a

3. Disconnect electronic cables from solenoid valve and handle (if installed).
4. Use 5/32 in. allen wrench to remove handle mounting plate screws. Remove handle mounting plate and handle. See **Component Identification** on page 18.
5. Use Phillips screwdriver to remove solenoid valve. Inspect and replace if necessary. Inspect gasket on bottom of solenoid valve and replace if necessary. See **Component Identification** on page 18.
6. Use a 9/64 in. allen wrench to remove the solenoid valve mounting plate and gasket. Inspect gasket and replace if necessary. See **Component Identification** on page 18.
7. Assemble in reverse order. Torque fluid manifold bolt to 20-30 in-lb (2.26-3.39 N•m). Torque screws connecting handle to body to 20-30 in-lb (2.26-3.39 N•m). See **Component Identification** on page 18.

Troubleshooting

						
Follow Pressure Relief Procedure , page 24, before checking or repairing gun.						

NOTICE

To prevent cross-contamination of the equipment's wetted parts, **never** interchange component A (isocyanate) and component B (resin) parts. The gun is shipped with the A side on the left. The fluid manifold, fluid housing, side seal assembly, check valve cartridge, and mix chamber are marked on the A side.

Use the following table to check all possible problems and causes before disassembling gun. See **Maintenance** on page 26 and **Repair** on page 32 for referenced procedures.

Problem	Cause	Solution
Gun does not fully actuate when triggered	Safety lock engaged	Disengage piston safety lock
	Plugged breather plug	Clean breather plug
	Damaged air valve	Replace if necessary
Fluid does not pour when gun is fully actuated	Closed fluid valves	Open valves.
	Plugged orifice ports	Clean orifice ports
	Plugged check valves	Clean check valves
	Safety lock engaged	Disengage piston safety lock
Gun actuates slowly	Plugged breather plug	Clean breather plug
	Damaged piston o-rings	Replace air piston o-rings
	Damaged air gasket	Replace
	Dirty or damaged air valve	Clean or replace valve
Gun delays, then actuates abruptly	Cured material around the purge rod	Inspect purge rod, mix module, and orifices. Replace if necessary
Gun does not actuate when triggered	Air supply to gun is shut off	Open air supply
	Foam build-up around front tip	1) Clean off front tip. 2) Use 3/4 in. wrench to loosen front tip 1/8 turn and re-tighten.
	Signal cable is disconnected	Connect signal cable
Pressure imbalance	Plugged orifice ports	Clean orifice ports
	Plugged check valves	Clean check valves
	Viscosities not equal	Adjust temperature or orifice needle to compensate
	Plugged fluid screens	Clean screens
Fluid does not shut off when fluid valves are closed	Damaged fluid valves	Replace

Problem	Cause	Solution
Burst of air from muffler when gun is triggered	Normal	No action required
Steady air leakage from muffler	Damaged air valve	Replace
	Damaged air gasket	Replace
	Damaged piston o-rings	Replace
Leak between air cylinder and fluid housing	Damaged o-ring	Replace
Material leaking out weep ports in fluid housing near air cylinder	Mix module and rear seal worn	Inspect and replace mix module and rear seal, clean fluid housing
Material is spraying out of nozzle	Flow rate is too high	Change one or more of the following variables to obtain a flow rate of 10 to 15 pounds per minute <ul style="list-style-type: none"> • Orifice size • Material Temperature

Electrical Diagram

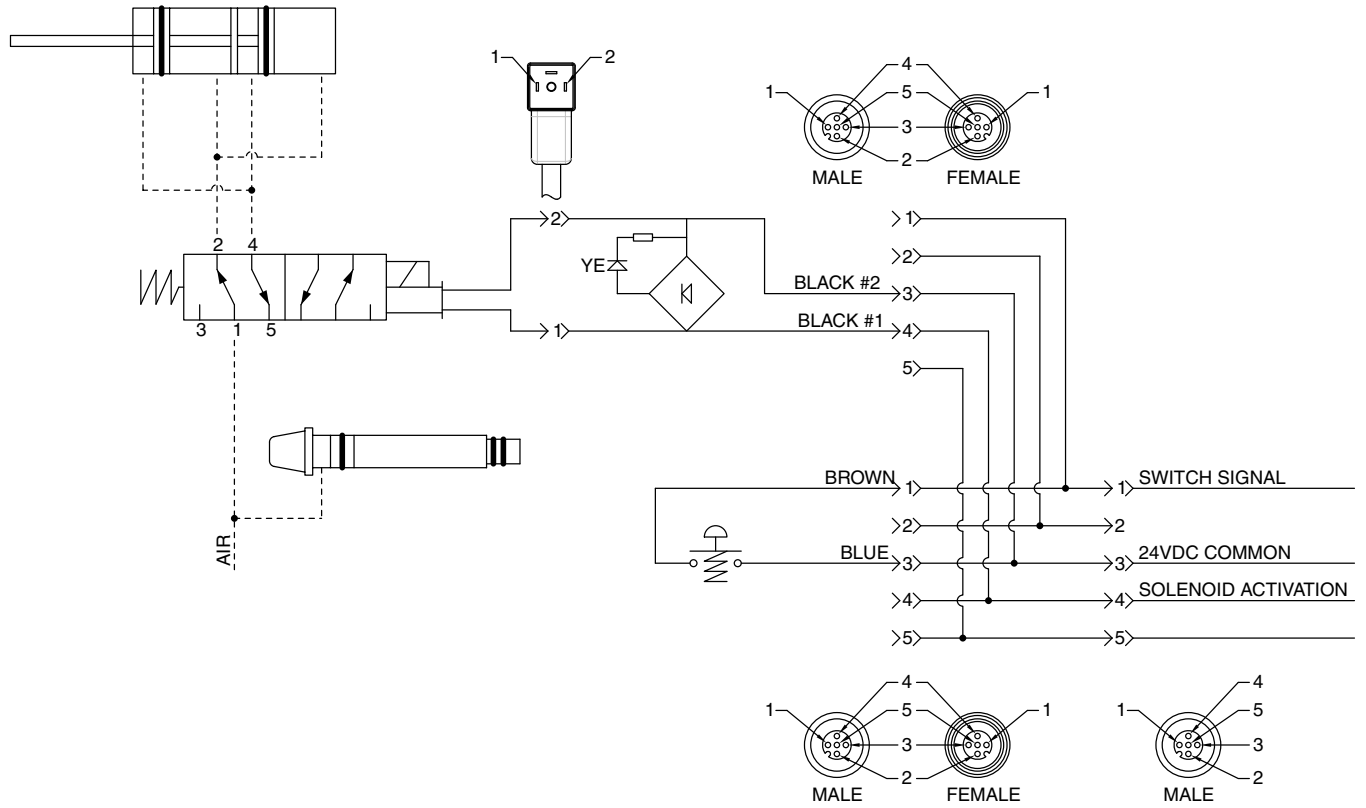

Parts

- Torque to 125-135 in-lb (14.1-15.3 N•m)
- Torque to 20-30 in-lb (2.26-3.39 N•m)
- Torque to 100-110 in-lb (11.3-12.4 N•m)
- Torque to 10-12 in-lb (1.13-1.36 N•m)
- Torque to 60-70 in-lb (6.78-7.91 N•m)
- Apply medium thread locker to threads

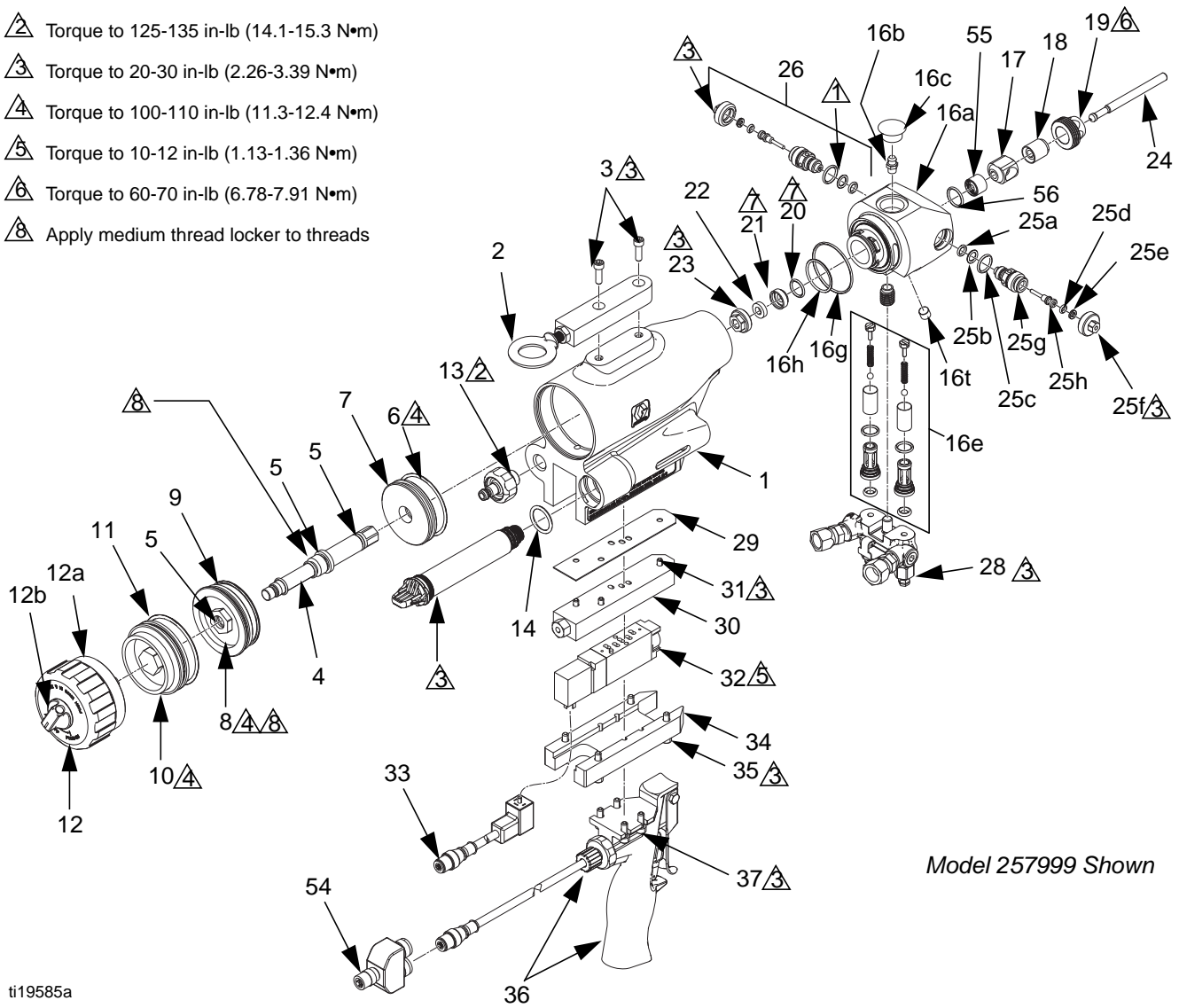

Model 257999 Shown

ti19585a

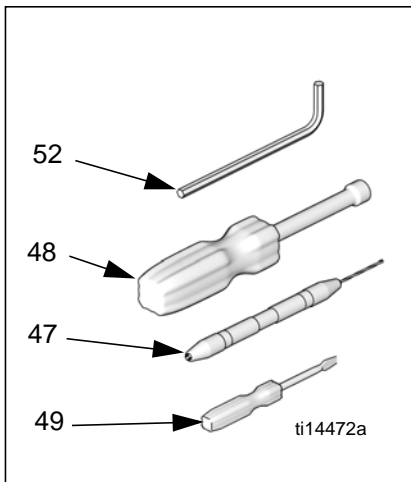

ti14472a

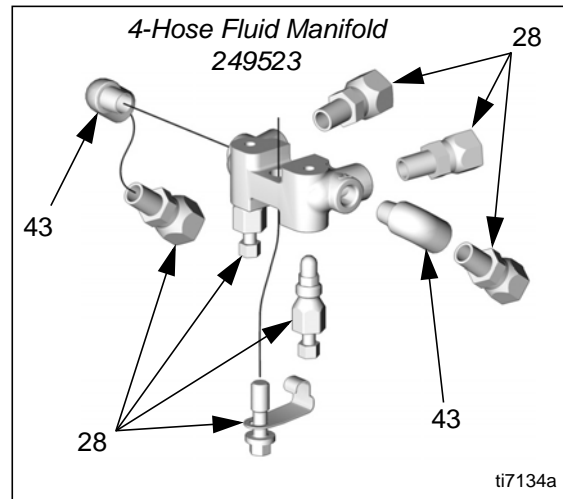

ti7134a

Ref	Part	Description	Quantity	
			257999, EP Gun, 250, 0.031 in. orifice, Handheld	24C932, EP Gun, 250, 0.031 in. orifice, Auto
1	24D682	CYLINDER, machined	1	1
2	24F033	HOOK, vertical mount assembly	1	1
3	113003	SCREW, socket head cap	2	2
4	24E864	SHAFT, piston, dual	1	1
5	◆	PACKING, o-ring	3	3
6	24E972	PISTON, front	1	1
7	◆	PACKING, o-ring	1	1
8	24E973	BULKHEAD, applicator	1	1
9	◆	PACKING, o-ring	1	1
10	24E974	PISTON, rear	1	1
11	◆	O-RING	1	1
12	24D295	STOP, assy, safety	1	1
13	15T897	PLUG, air valve	1	1
14	188554	PACKING, o-ring	1	1
15		PIN, roll	1	1
16a	⊗	HOUSING, fluid, assy, 250	1	1
16b	295229⊗	FITTING, grease, 1/4-28	1	1
16c	1704-2⊗	PLUG, hole DP-750	1	1
16e	⊗*⊗	VALVE, check	1	1
16g	248132◆⊗	O-RING, outer housing	1	1
16h	256773◆⊗	PACKING, o-ring 022	1	1
16t	⊗	PLUG, pipe	1	1
17	*‡⊗	MODULE, mix, 250 rod	1	1
18	16P943*‡⊗	PACKING, front, 250 rod	1	1
19	16T794⊗	TIP, pour, 250 rod	1	1
20	***⊗	PACKING, o-ring	6	6
21	15Y980⊗	HOUSING, packing, rear, 250 rod	1	1
22	***‡⊗	SEAL	6	6
23	24D678⊗	NUT, packing, rear, 250	1	1
24	24D317⊗	ROD, purge, 250	1	1
25	†	RESTRICTOR, adjustable, 250, 031	2	2
26	†	RESTRICTOR, adjustable, iso, 250, 031	2	2
28	246012	MANIFOLD, fluid	1	1
29	24D315	GASKET, solenoid, manifold	1	1
30	24E975 ★	MANIFOLD, solenoid, assy	1	1
31	106245	SCREW, socket head cap	3	3
32	24M121 ★	VALVE, solenoid, 4 way	1	1
33	24M122 ★	CORD SET, euro/male, din/female	1	1
34	24E865 ★	PLATE, adapter, handle	1	1
35	101888 ★	SCREW, socket head cap	4	4

Ref	Part	Description	Quantity	
			257999, EP Gun, 250, 0.031 in. orifice, Handheld	24C932, EP Gun, 250, 0.031 in. orifice, Auto
36	24D073	HANDLE, 2k dispense	1	
37	C19980	SCREW, cap, socket hd	4	
41	172479 ▲	TAG, warning	1	1
43	112307	ELBOW, street	2	2
44	117510	COUPLER, line, air, 1/4 npt	1	1
45	15B772	HOSE, air, 18 inch	1	1
46	15B565	VALVE, ball	1	1
47	117661	PIN, vise	1	1
48	117642	TOOL, nut driver	1	1
49	118575	TOOL, screw driver, 1/8 blade	16g 1	1
51	222385 ▲	TAG, warning	1	1
52	295598	TOOL, wrench, hex	1	16h 1
54	24D320	CONNECTOR, splitter	1	
55	**⊠	SCRAPER, assembly	1	1
56	115719 **⊠	PACKING, o-ring, 015	1	1

▲ Replacement Danger and Warning labels, tags and cards are available at no cost.

* Parts included in Kit 16T549.

** Parts included in Kit 16T531.

*** Parts included in Kit 24E252.

◆ Parts included in Kit 24D312.

❖ Parts included in Kit 24D313.

♣ Parts included in Kit 246352.

⊠ Parts included in Kit 246731.

⊠ Parts included in Kit 16T553.

† See **Orifice Kits** section starting on page 51.

‡ Suggested spares. These parts should be kept on-hand to prevent down time. Kits 24D321, 246731, 246352 should also be kept on-hand. See **Kits** starting on page 45 for contents of each kit.

★ If installed gun components are prior to October 2011, kit 24M123 is necessary when replacing components.

Kits

See **Maintenance** on page 26 and **Repair** on page 32 for appropriate kit installation procedures. See **Complete O-ring Placement Guide** on page 54 for o-ring identification help.

Series A and B Kits

The following kits are for series A and B guns only. Series A and B guns utilize the TSL cartridge for lubrication of the purge rod and the front head assembly does not contain a scraper.

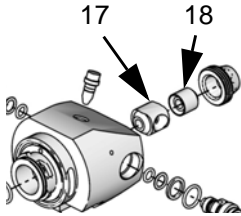
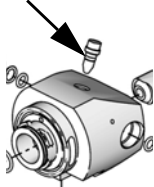
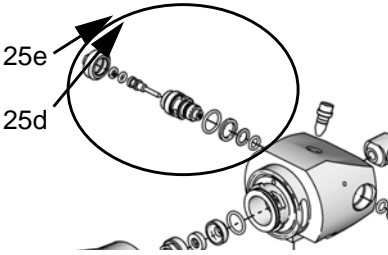
Kit Description	Kit Number	Parts included in Kit		Illustration
		Description	Qty	
250 Mix Chamber	24D314	Mix Chamber	1	
		Front Bearing	1	
375 Mix Chamber	24D322	Mix Chamber	1	
		Front Bearing	1	
Throat Seal Liquid Bleed Port O-Ring Kit	246354	O-Ring	6	
		O-Ring Installation Tool	1	
375 Iso Orifice	24D239 - 24D254; see Orifice Kits on page 52	Orifice Housing	1	
		O-Ring	1	
		O-Ring	1	
		O-Ring	1	
		Needle	1	
		Backup Ring	1	
		O-Ring	1	
		Iso Orifice Cap	1	
		Orifice Spacer	1	
		Cleanout Drill	1	

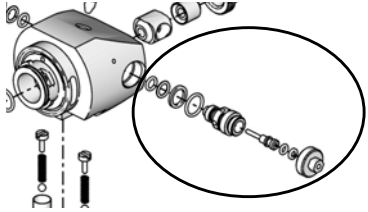
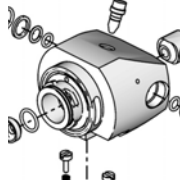
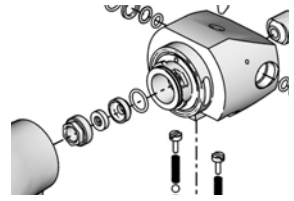
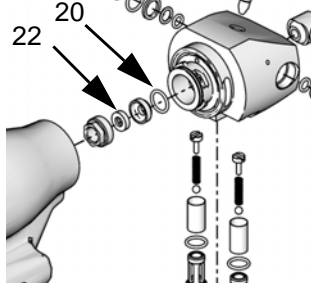
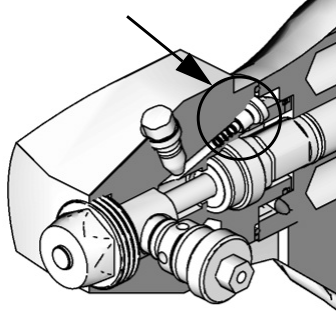
Kit Description	Kit Number	Parts included in Kit		Illustration
		Description	Qty	
375 Orifice	24C761 - 24C766, 24C794 - 24C804; see Orifice Kits on page 52	Orifice Housing	1	
		O-Ring	1	
		O-Ring	1	
		O-Ring	1	
		Needle	1	
		Backup Ring	1	
		O-Ring	1	
		Orifice Cap	1	
		Orifice Spacer	1	
		Cleanout Drill	1	
Fluid Housing Seals	24D313	Housing Outer O-Ring	1	
		Housing Inner O-Ring	1	
Outer Fluid Housing O-Ring Kit	24E611	O-Ring	6	
375 Lip Seal	24D325	375 Lip Seal	6	
TSL Check Valve Kit	24B843	Check Valve Seat	1	
		Ball	1	
		Spring	1	
		O-Ring	1	

All Series Kits

The following kits are for all series EP guns.

Kit Description	Kit Number	Parts included in Kit		Illustration
		Description	Qty	
250 Iso Ori- fice	24D223 - 24D238; see Orifice Kits on page 52	Orifice Housing	1	
		O-Ring	1	
		O-Ring	1	
		O-Ring	1	
		Needle	1	
		Backup Ring	1	
		O-Ring	1	
		Iso Orifice Cap	1	
		Cleanout Drill	1	
250 Orifice	24C751 - 24C756, 24C805 - 24C815; see Orifice Kits on page 52	Orifice Housing	1	
		O-Ring	1	
		O-Ring	1	
		O-Ring	1	
		Needle	1	
		Backup Ring	1	
		O-Ring	1	
		Orifice Cap	1	
		Cleanout Drill	1	
Orifice O-Ring Kit	24D321	O-Ring	1	
		O-Ring	1	
		O-Ring	1	
		O-Ring	1	
		Backup Ring		
Orifice O-Ring Kit	248130	O-Ring	6	

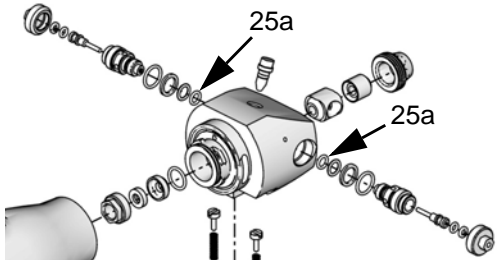
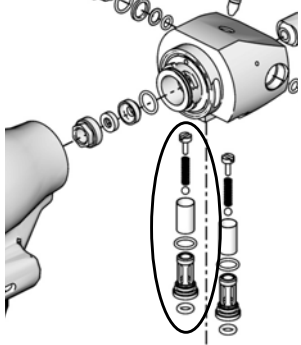
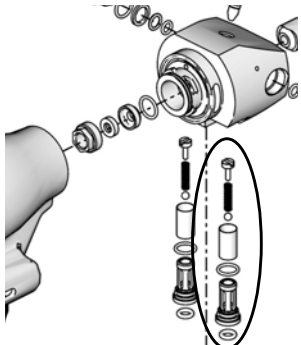
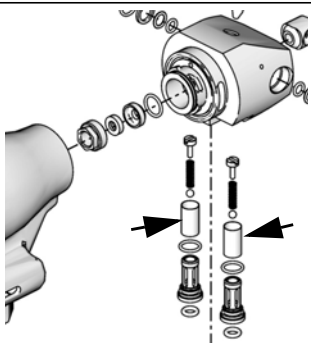
Kit Description	Kit Number	Parts included in Kit		Illustration
		Description	Qty	
Orifice O-Ring Kit	248128	O-Ring	6	
Iso Check Valve	246731	Check Valve Housing	1	
		Spring Retaining Screw	1	
		Carbide Ball	1	
		Filter	1	
		Check Valve Spring	1	
		O-Ring	1	
		O-Ring	1	
Check Valve	246352	Check Valve Housing	1	
		Spring Retaining Screw	1	
		Carbide Ball	1	
		Filter	1	
		Check Valve Spring	1	
		O-Ring	1	
		O-Ring	1	
40 Mesh Filter Kit (40 mesh, 0.015 in., 375 micron)	246357	40 Mesh Screen	10	
60 Mesh Filter Kit (60 mesh, 0.010 in., 238 micron)	246358	60 Mesh Screen	10	
80 Mesh Filter Kit (80 mesh, 0.007 in., 175 micron)	246359	80 Mesh Screen	10	

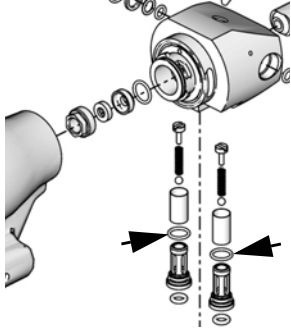
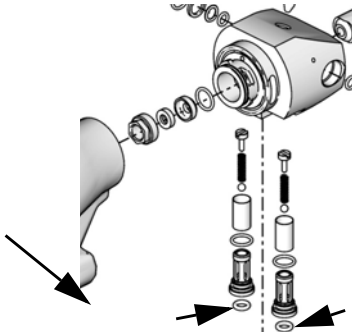
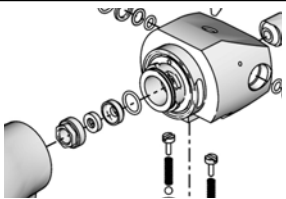
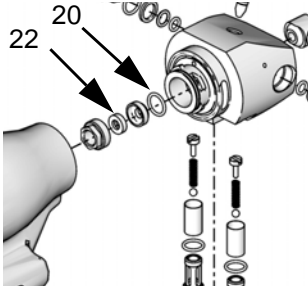
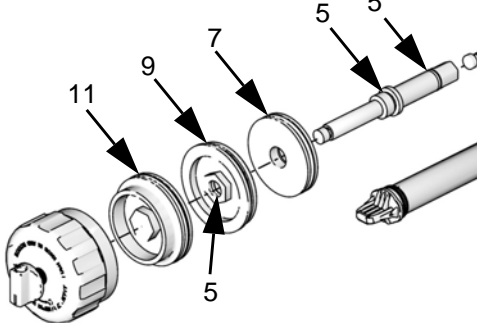
Kit Description	Kit Number	Parts included in Kit		Illustration
		Description	Qty	
Check Valve O-Ring Kit	248129	O-Ring	6	
Check Valve Face O-Ring Kit	248133	O-Ring	6	
Inner Fluid Housing O-Ring Kit	256773	O-Ring	6	
250 Lip Seal	24E252	250 Lip Seal	6	
		O-Ring	6	
Piston Seals	24D312	Rod O-Ring	3	
		Front Piston O-Ring	1	
		Bulkhead O-Ring	1	
		Rear Piston O-Ring	1	

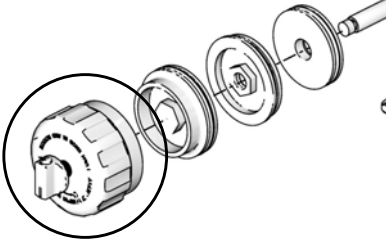
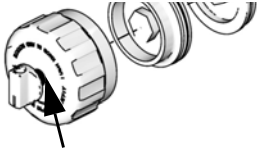
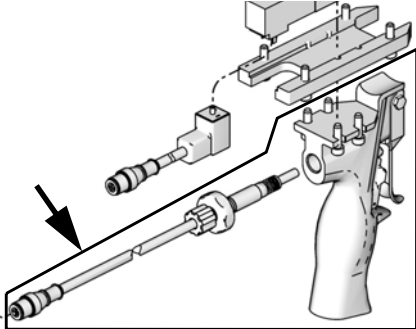
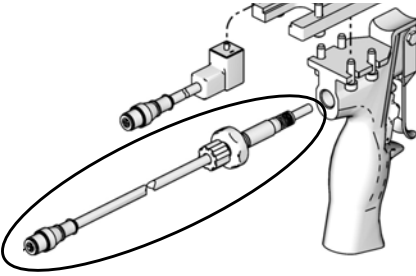
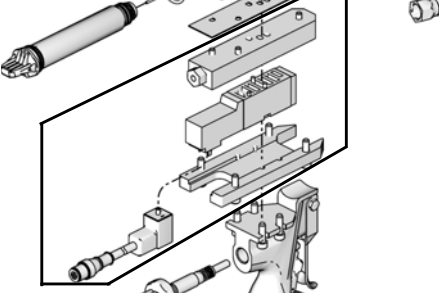
Kit Description	Kit Number	Parts included in Kit		Illustration
		Description	Qty	
Piston Safety Stop	24D295	Back Cap	1	
		O-Ring	1	
		Piston Stop	1	
		Safety Stop Shaft	1	
		O-Ring	1	
		Spring	1	
Stop Shaft O-Ring Kit	257425	O-Ring	6	 <p><i>Located inside back cap</i></p>
Handle	24D073	2K Electric Handle	1	
		Handle Mounting Screw	4	
Trigger Switch Harness	24D049	Trigger Switch	1	
		Switch Spacer	1	
		Air Valve Plug	1	
		Strain Relief	1	
		Signal Cable	1	
EP Solenoid Conversion (Required for components prior to October 2011)	24M123	Solenoid Valve	1	
		Cord Set	1	
		Screw	4	
		Adapter Plate	1	
		Solenoid Mount	1	

Series C Kits

The following kits are for series C guns only. Series C guns do not utilize the TSL cartridge for lubrication of the purge rod and the front head assembly does contain a scraper.

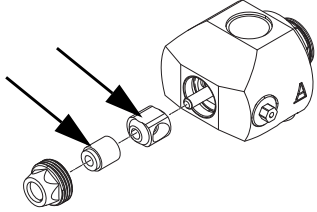
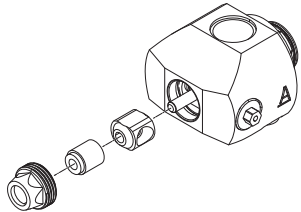
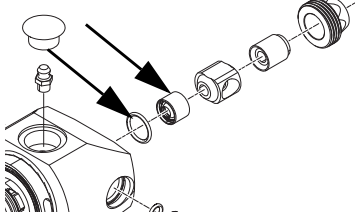
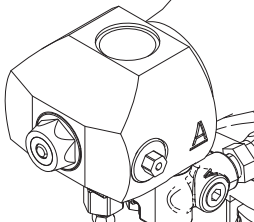
Kit Description	Kit Number	Parts included in Kit		Illustration
		Description	Qty	
250 Mix Chamber (Requires 16T794 if using series A fluid housing)	16T549	Mix Chamber	1	
		Front Bearing	1	
Pour Tip	16T794	Pour Tip	1	
Scraper Cartridge	16T531	Scraper Cartridge	1	
		O-ring	1	
Fluid Housing Kit (Orifices sold separately)	16T553	Fluid Housing with centerline components	1	
		Grease Gun	1	
		Grease	1	
		TSL	1	



















Orifice Kits

In the following table, shaded rows indicate “Super Standard” items that are typically stocked and provide the best delivery dates.

Impingement Port Size		Kit Type and Kit Number	
		250 Model Polyol Orifice Kit	250 Model Iso Orifice Kit
in.	mm		
0.016	0.41	24C805	24D229
0.020	0.51	24C751	24D223
0.024	0.61	24C806	24D230
0.028	0.71	24C807	24D231
0.031	0.79	24C752	24D224
0.035	0.89	24C808	24D232
0.039	0.99	24C809	24D233
0.042	1.07	24C810	24D234
0.047	1.19	24C753	24D225
0.052	1.32	24C811	24D235
0.055	1.40	24C812	24D236
0.060	1.52	24C754	24D226
0.063	1.60	24C813	24D237
0.067	1.70	24C755	24D227
0.073	1.85	24C815	24D238
0.086	2.18	24C756	24D228
All 250 Super Standard Orifices		24E250	

Drill Bit Kits

For cleaning fluid housing passages and orifices. Drill bit illustrations are actual size for comparison. See **Clean Fluid Housing Passages** on page 30. Not all sizes are used with every gun model.

Kit Number	Drill Bit Size	Qty in Kit	Orifice Size		Illustration
			in.	mm	
24D289	#78	6	0.016	0.41	
246631	#76	6	0.020	0.51	
246815	#73	6	0.024	0.61	
248892	#70	6	0.028	0.71	
24D293	#68	6	0.031	0.79	
24D294	#65	6	0.035	0.89	
248640	#61	6	0.039	0.99	
246629	#58	6	0.042	1.07	
249764	#56	6	0.047	1.20	
246628	#55	6	0.052	1.32	
246809	#54	6	0.055	1.40	
246627	#53	6	0.060	1.52	
249113	1/16 in.	6	0.063	1.60	
24D290	#51	6	0.067	1.70	
24D291	#49	6	0.073	1.85	
246625	#44	3	0.086	2.18	
246624	3/32 in.	3	0.094	2.39	
249115	1/8 in.	6	0.125	3.18	
24D327	#15	1	0.180	4.57	

Complete O-ring Placement Guide

The following illustration shows all gun o-rings at actual size. See **Kits** on page 45 for o-ring kit details including quantities of each o-ring in each kit.

See **Parts** on page 42 for part references and locations.

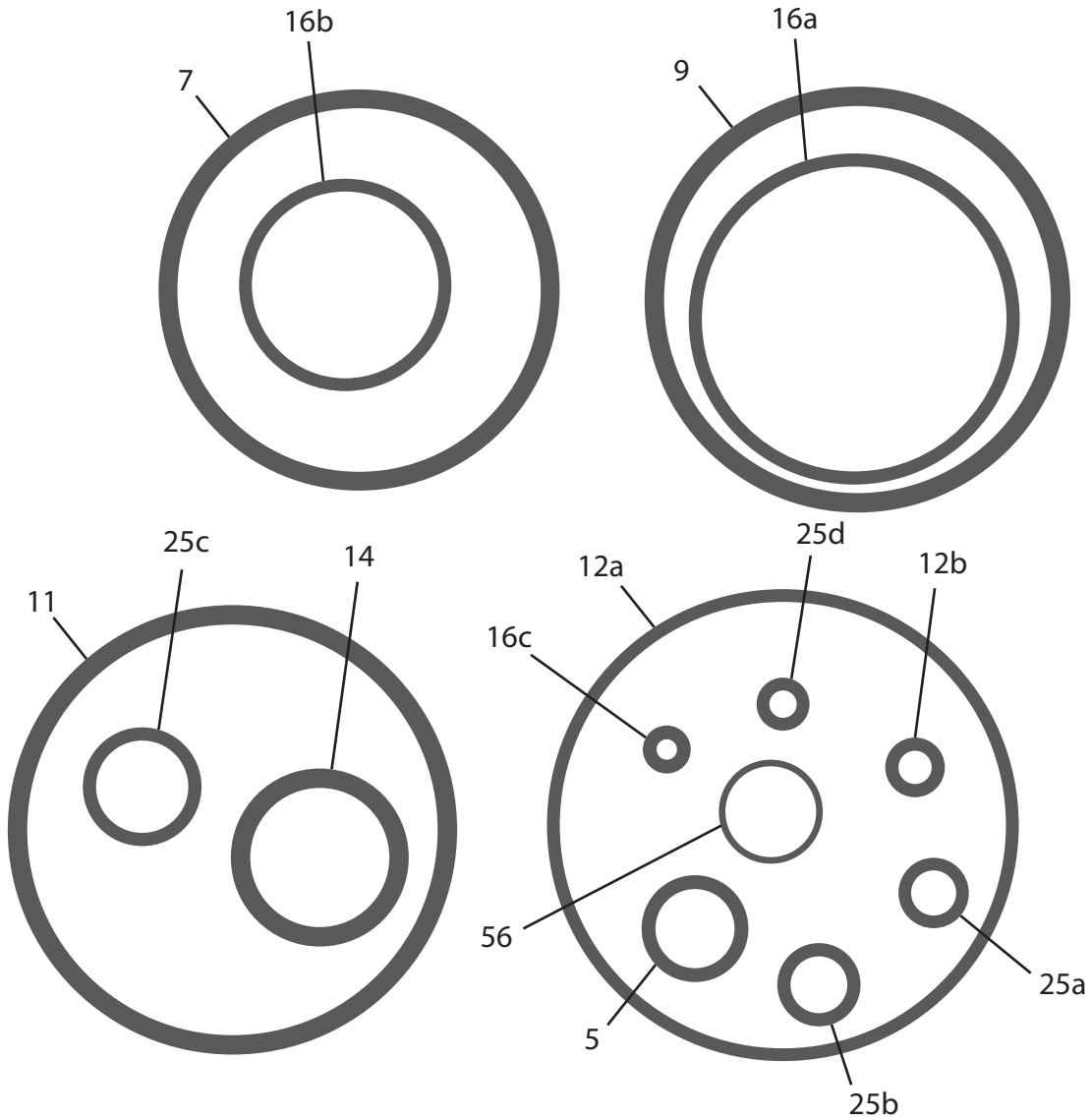

Accessories

Lubricant for Gun Rebuild

NOTICE

Use only Throat Seal Liquid on the o-rings, seals, and threads of the cartridge. Fusion grease or other petroleum-based or vegetable-based lubricants will cause cartridge o-rings and seals to swell and stick.

248279, 4 oz (113 gram) [10]

High adhesion, water resistant, lithium-based lubricant. MSDS sheet available at www.graco.com.

Fluid Inlet Cover

15C850 Recirculation Block



Gun Cleaning Kit

15D546

Kit includes gun pick, tip cleaning tool, o-ring tool, utility knife and blades, and seven different brushes.

Flushing Manifold

15B817 Manifold Block

Attaches to gun fluid manifold to enable flushing.

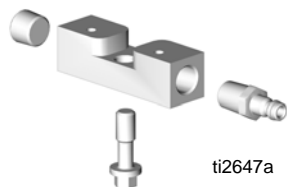

Circulation Manifold

246362

Attaches to gun fluid manifold to enable preheating of hose. See manual 309818.

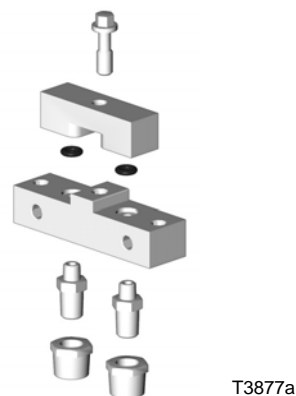

Reactor[®] IP Harness

24D679

Attaches to gun signal cable to enable connection to Reactor IP proportioners. 10 ft cable, male 9-pin to female 5-pin.

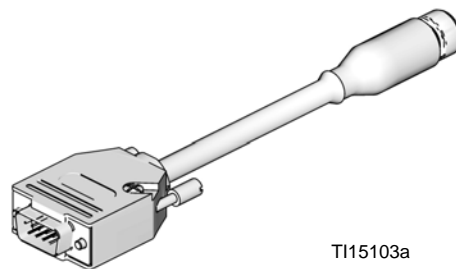

Signal Cable Extensions

24E898

25 ft extension cable, male 5-pin to female 5-pin.

24E897

50 ft extension cable, male 5-pin to female 5-pin.

Solvent Flush Canister Kit

248139, 1 qt (0.95 liter) Solvent Cup

Includes flushing manifold to flush gun with solvent. Portable for remote flushing. See manual 309963.

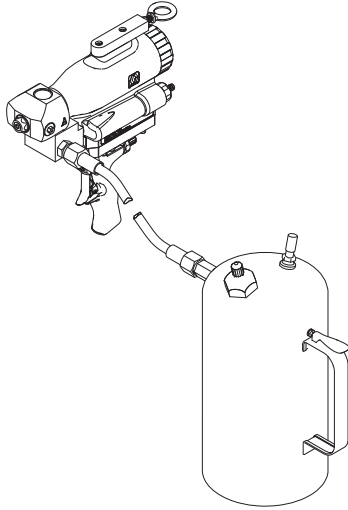

ti19567a

Grease Cartridge for Gun Shutdown

248280 Cartridge, 3 oz [10]

Specially formulated low viscosity grease flows easily through gun passages, to prevent two-component curing and keep fluid passages clean.

Solvent Flush Pail Kit

248229, 5.0 gal. (19 liter) Pail

Includes flush manifold with individual A and B shutoff valves, and air regulator. See manual 309963.

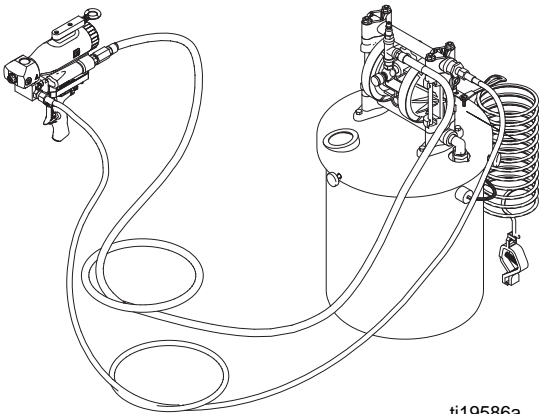

ti19586a

Technical Data

Maximum Fluid Working Pressure	3000 psi (20.7 MPa, 207 bar)
Minimum Air Inlet Pressure.	80 psi (0.55 MPa, 5.5 bar)
Maximum Air Inlet Pressure	100 psi (0.69 MPa, 6.9 bar)
Maximum Fluid Temperature	180°F (82°C)
Air Inlet Size	1/4 npt Quick Disconnect Nipple
A Component Inlet Size	-5 JIC, 1/2 - 20 UNF
B Component Inlet Size	-6 JIC, 9/16 - 18 UNF
Weight.	<i>Models with Handle:</i> 7.4 lb (3.4 kg) <i>Models without Handle:</i> 6.4 lb (2.9 kg)
Sound pressure	80.22 dB(A) at 100 psi (0.7 MPa, 7 bar)
Sound power, measured per ISO 9416-2	80.64 dB(A) at 100 psi (0.7 MPa, 7 bar)
Materials of Construction	Aluminum, stainless steel, acetal, chemically resistant o-rings, carbon steel, fluoroelastomer o-rings
Wetted Parts	Aluminum, stainless steel, acetal, chemically resistant o-rings

Dimensions

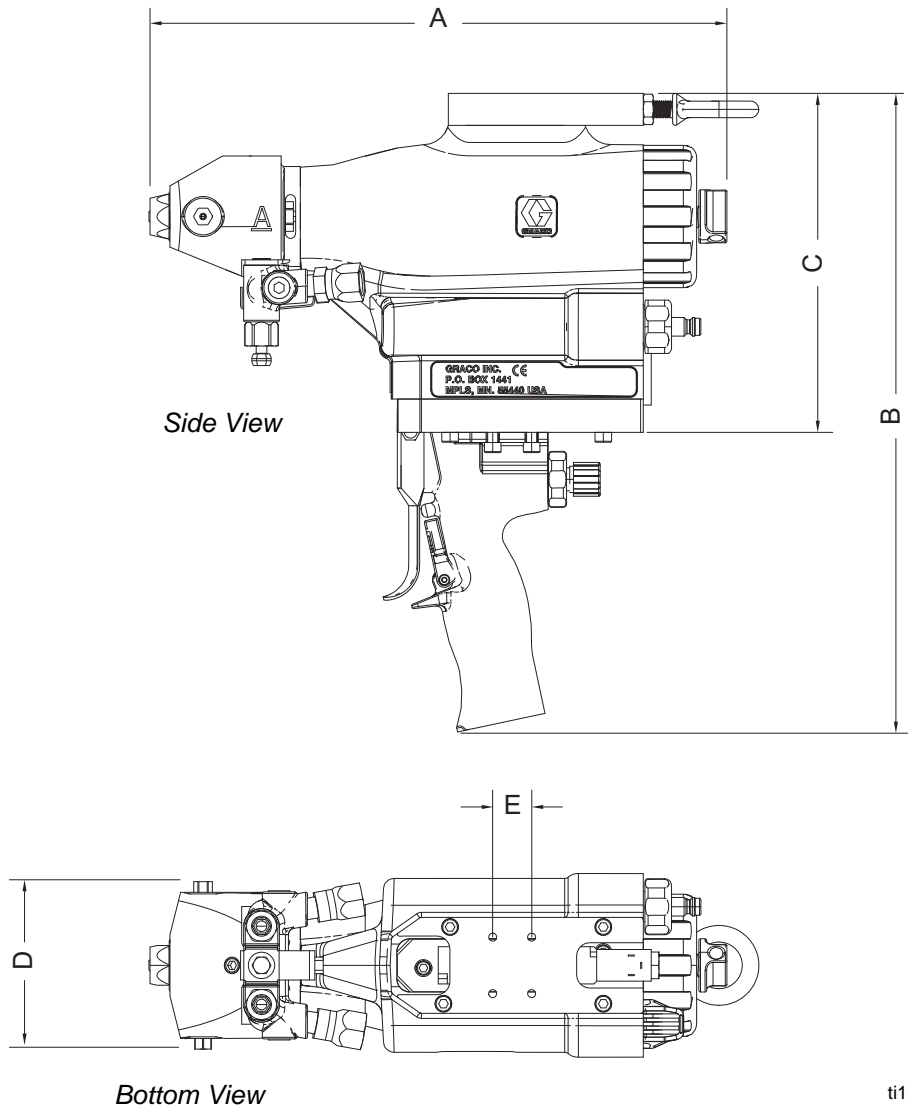

ti19587a

Ref Dimension, in. (mm)

A	10.8 (274)
B	11.7 (297)
C	6.1 (155)
D	3.1 (79)
E	0.73 (19)
F	1.06 (27); Mounting: 4x 10-24

Graco Standard Warranty

Graco warrants all equipment referenced in this document which is manufactured by Graco and bearing its name to be free from defects in material and workmanship on the date of sale to the original purchaser for use. With the exception of any special, extended, or limited warranty published by Graco, Graco will, for a period of twelve months from the date of sale, repair or replace any part of the equipment determined by Graco to be defective. This warranty applies only when the equipment is installed, operated and maintained in accordance with Graco's written recommendations.

This warranty does not cover, and Graco shall not be liable for general wear and tear, or any malfunction, damage or wear caused by faulty installation, misapplication, abrasion, corrosion, inadequate or improper maintenance, negligence, accident, tampering, or substitution of non-Graco component parts. Nor shall Graco be liable for malfunction, damage or wear caused by the incompatibility of Graco equipment with structures, accessories, equipment or materials not supplied by Graco, or the improper design, manufacture, installation, operation or maintenance of structures, accessories, equipment or materials not supplied by Graco.

This warranty is conditioned upon the prepaid return of the equipment claimed to be defective to an authorized Graco distributor for verification of the claimed defect. If the claimed defect is verified, Graco will repair or replace free of charge any defective parts. The equipment will be returned to the original purchaser transportation prepaid. If inspection of the equipment does not disclose any defect in material or workmanship, repairs will be made at a reasonable charge, which charges may include the costs of parts, labor, and transportation.

THIS WARRANTY IS EXCLUSIVE, AND IS IN LIEU OF ANY OTHER WARRANTIES, EXPRESS OR IMPLIED, INCLUDING BUT NOT LIMITED TO WARRANTY OF MERCHANTABILITY OR WARRANTY OF FITNESS FOR A PARTICULAR PURPOSE.

Graco's sole obligation and buyer's sole remedy for any breach of warranty shall be as set forth above. The buyer agrees that no other remedy (including, but not limited to, incidental or consequential damages for lost profits, lost sales, injury to person or property, or any other incidental or consequential loss) shall be available. Any action for breach of warranty must be brought within two (2) years of the date of sale.

GRACO MAKES NO WARRANTY, AND DISCLAIMS ALL IMPLIED WARRANTIES OF MERCHANTABILITY AND FITNESS FOR A PARTICULAR PURPOSE, IN CONNECTION WITH ACCESSORIES, EQUIPMENT, MATERIALS OR COMPONENTS SOLD BUT NOT MANUFACTURED BY GRACO. These items sold, but not manufactured by Graco (such as electric motors, switches, hose, etc.), are subject to the warranty, if any, of their manufacturer. Graco will provide purchaser with reasonable assistance in making any claim for breach of these warranties.

In no event will Graco be liable for indirect, incidental, special or consequential damages resulting from Graco supplying equipment hereunder, or the furnishing, performance, or use of any products or other goods sold hereto, whether due to a breach of contract, breach of warranty, the negligence of Graco, or otherwise.

FOR GRACO CANADA CUSTOMERS

The Parties acknowledge that they have required that the present document, as well as all documents, notices and legal proceedings entered into, given or instituted pursuant hereto or relating directly or indirectly hereto, be drawn up in English. Les parties reconnaissent avoir convenu que la rédaction du présente document sera en Anglais, ainsi que tous documents, avis et procédures judiciaires exécutés, donnés ou intentés, à la suite de ou en rapport, directement ou indirectement, avec les procédures concernées.

Graco Information

For the latest information about Graco products, visit www.graco.com.

TO PLACE AN ORDER, contact your Graco distributor or call to identify the nearest distributor.

Phone: 612-623-6921 **or Toll Free:** 1-800-746-1334 **Fax:** 330-966-3006

*All written and visual data contained in this document reflects the latest product information available at the time of publication.
Graco reserves the right to make changes at any time without notice.*

For patent information, see www.graco.com/patents.

Original instructions. This manual contains English. MM 313872

Graco Headquarters: Minneapolis

International Offices: Belgium, China, Japan, Korea

GRACO INC. AND SUBSIDIARIES • P.O. BOX 1441 • MINNEAPOLIS MN 55440-1441 • USA

Copyright 2010, Graco Inc. All Graco manufacturing locations are registered to ISO 9001.

www.graco.com

Revision P, September 2015